

Fixed Magnetic Whiteboard on Heavy Duty T-Slot Mobile Stand | 3ft x 4ft | 4ft x 4ft

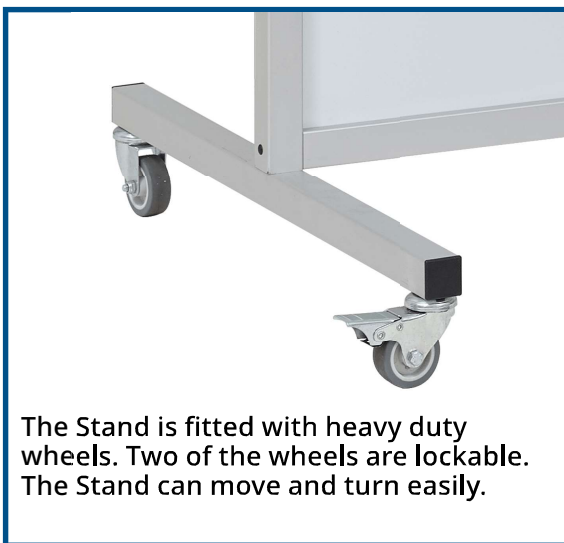
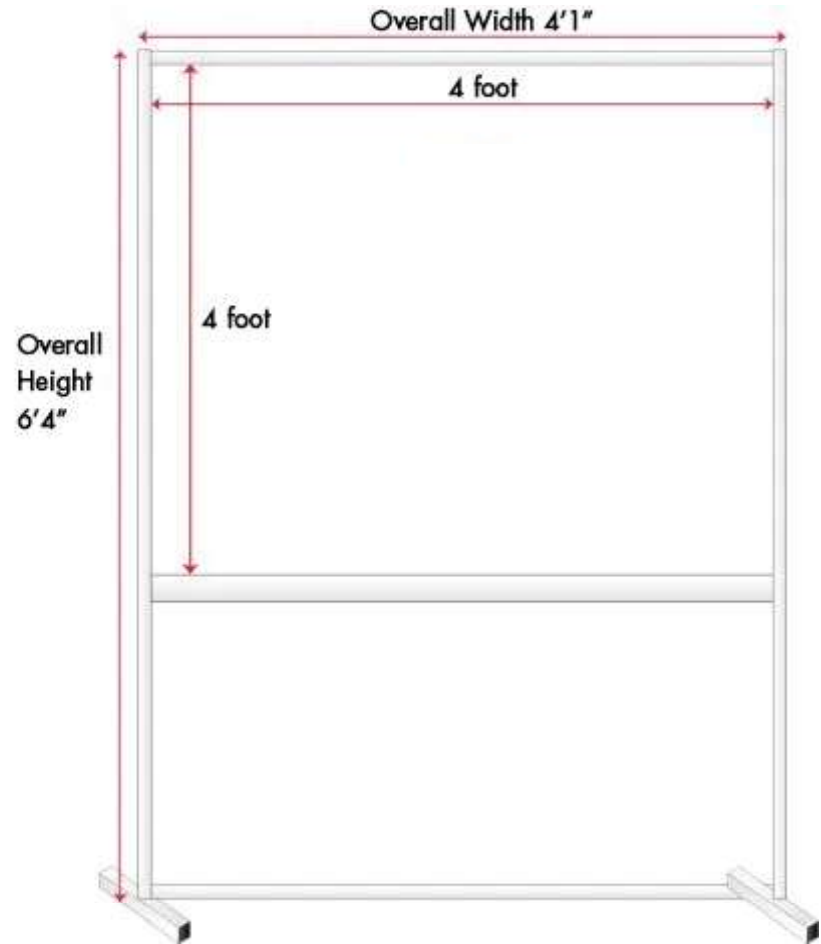
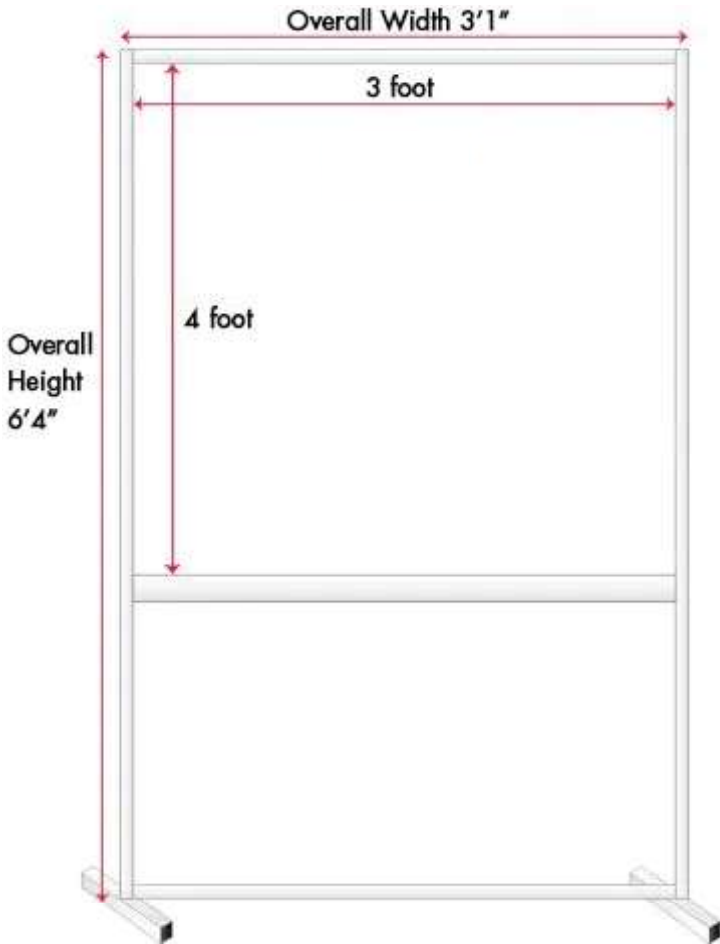

INFO:

- Ideal for call centers, huddle points and production environments.
- Extra robust 1" x 1" frame
- Custom Sizes Available
- Magnetic coated steel whiteboard surface
- Plain boards: Lead time is typically 2-3 weeks
- Custom printed Boards: Lead time typically is 2-3 weeks from sign off of digital proof
- Lead times subject to change
- Height: 76"
- 10 year surface guarantee

Technical Data

Components and Material	
Core panel substrate	Hard board backer
Panel Gauge	1/4"
Surface	Coated 26 gauge steel. Steel surface accepts magnets.
Aluminium Frame	Anodised aluminum 1.2" x 1.2". Powder coated on request.
Packaging	Product is shipped on a Pallet. Customer is responsible for having either a loading dock or a fork lift to use to get the shipment off the back of the truck and into their building.
Board Dimensions	The board dimensions in the product descriptions are approximate. The exterior dimensions of this product is +0.4" on the width and +0.4" on the height. All tolerances are +2"/-2". Any precise overall measurements can be requested through customer services at time of ordering.
Care and Maintenance	<ol style="list-style-type: none">1. To prevent spreading the written ink, only wipe when it's completely dry. This is crucial with lacquered and printed boards because the solvents in the ink will cause damage to the board surface.2. Only use dry erase pens with a clean felt or paper wiper suitable for whiteboards.3. Daily clean the board with cleaning spray to maintain a good erasability.4. NEVER use other cleaning agents than real whiteboard cleaners. Aggressive cleaners like Windex will cause permanent damage to the board surface.5. When a wrong marker (flipchart marker, permanent marker) is used by accident: immediately clean the board with cleaning spray and a microfiber cloth. If that doesn't help, write over the written text with a whiteboard marker until it desolves. Clean the board with cleaning spray afterwards. Note: Some markers - even those of renowned brands- are poorly erasable.
Guarantee	Subject to proper use in accordance with the care and maintenance instructions: 10 years surface guarantee