

# Magnetic Whiteboards Cube Cabinets - Midi

## Outside Dimensions

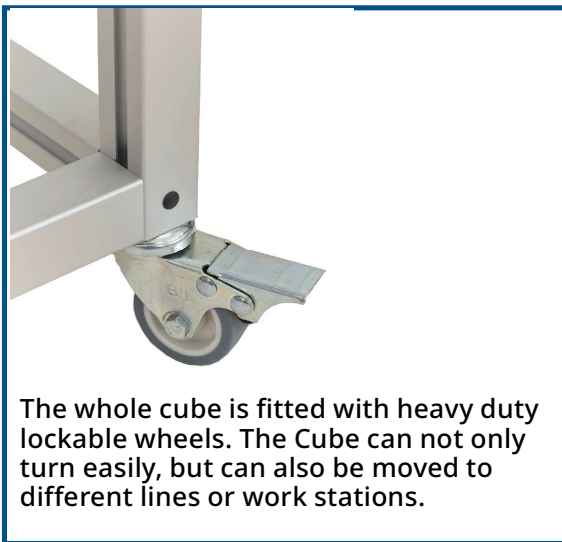
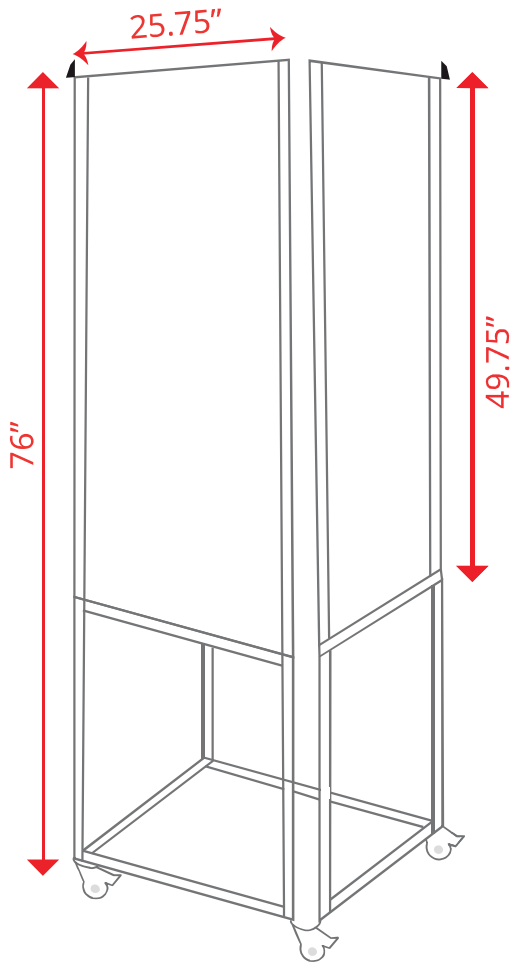

The whole cube is fitted with heavy duty lockable wheels. The Cube can not only turn easily, but can also be moved to different lines or work stations.

## INFO:

- Ideal for call centers, huddle points and production environments.
- Includes door with 1 shelf
- Custom Print Options
- Custom Sizes Available
- Magnetic coated steel whiteboard surface
- Plain boards: Lead time is typically 2-3 weeks
- Custom printed Boards: Lead time is 2-3 weeks from sign off of digital proof
- Lead times subject to change
- Board Outside dimensions: 25.75" x 49.5"
- Height: 76"
- 10 year surface guarantee

# Technical Data

<b>Components and Material</b>	
<b>Core panel substrate</b>	Lightweight Honeycomb.
<b>Panel Gauge</b>	0 35"
<b>Surface</b>	Coated steel 0.02" and galvanized steel backboard 0.02". Steel surface accepts magnets.
<b>Aluminium Frame</b>	Anodised aluminum 1.2" x 1.2". Powder coated on request.
<b>Packaging</b>	Corrugated cardboard made entirely from recycled papers and 100% recyclable. Standard packaging tape. Self adhesive paper label. Packed on a pallet. Includes minimum of outer card layer pad sheet pallet wrap and secured with polyester strapping and a metal buckle. Document wallet with delivery note enclosed (1 per consignment).
<b>Cube Dimensions</b>	Each whiteboard panel is 2ft w x 4ft h Outside dimensions: 25.75" x 49.75" The overall cube size including frame is 25.75"w x 75" h
<b>Certificates and Standards</b>	EN ISO14001: 2004 BS6250 – Part 3 Resistance to Heat / Blistering BS3900 – Part D5 Surface Gloss Levels (Erasability) BS5669 – Part 2 Boards Construction / Composition BS3962 – Part 6 Resistance to Wear and Scratching
<b>Care and Maintenance</b>	<ol style="list-style-type: none"> <li>1. To prevent spreading the written ink, only wipe when it's completely dry. This is crucial with lacquered and printed boards because the solvents in the ink will cause damage to the board surface.</li> <li>2. Only wipe dry ink with a clean (!) felt or paper wiper suitable for whiteboards.</li> <li>3. Daily clean the board with cleaning spray to maintain a good erasability.</li> <li>4. NEVER use other cleaning agents than real whiteboard cleaners. Aggressive cleaners like Windolene will cause permanent damage to the board surface.</li> <li>5. When a wrong marker (flipchart marker, permanent marker) is used by accident: immediately clean the board with cleaning spray and a microfiber cloth. If that doesn't help, write over the written text with a whiteboard marker until it desolves. Clean the board with cleaning spray afterwards.</li> </ol> <p>Note! Some markers - even those of renowned brands- are poorly erasable.</p>
<b>Guarantee</b>	Subject to proper use in accordance with the care and maintenance instructions: 10 years surface guarantee