

# Magnetic Reversible Mobile Whiteboard







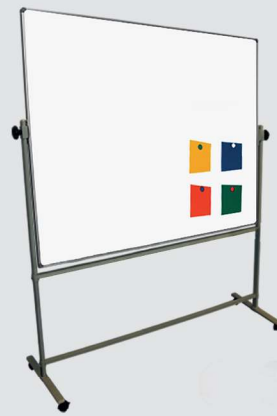

## ~ Assembly Instructions ~

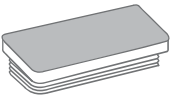
### What you will have:

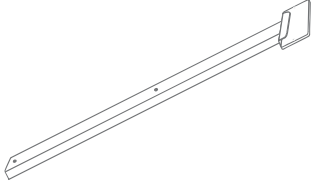
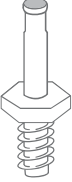
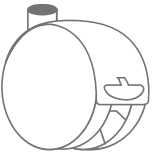
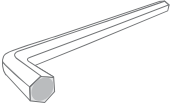
6 x End caps	A
2 x Caster Bar	B
2 x Uprights	C
4 x Caster Shafts	D
4 x Casters	E
1 x 3mm Allen Key	F
8 x M5 16mm Bolts	G
1 x 5mm Allen Key	H
4 x M8 Bolts 50MM	I
2 x Cross Members	J + K
2 x Swivel Mechanism	L
2 x Rubber Washer	M
2 x Locking Handles	N

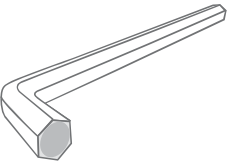
### Finished Product:

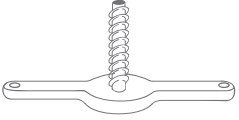
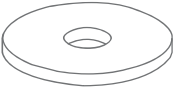
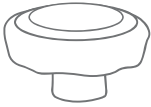

A x 6 	B x 2 	C x 2 	D x 4 
E x 4 	F x 1 	G x 8 	H x 1 
I x 4 	J x 1 	K x 1 	L x 2 
M x 2 	N x 2 		

Before you use your new whiteboard for the first time make sure you clean all the panels thoroughly.

If you have any further enquiries on how to fit your whiteboard please contact our customer service team.

# Magnetic Reversible Mobile Whiteboard

## ~ Assembly Instructions ~

### STEP ONE

Fit 4 of the end caps (A) on to both ends of the caster bars (B), fit the last two remaining end caps on to the open ends of the upright members (C). Tap the end caps on with a mallet to ensure they are fully inserted.

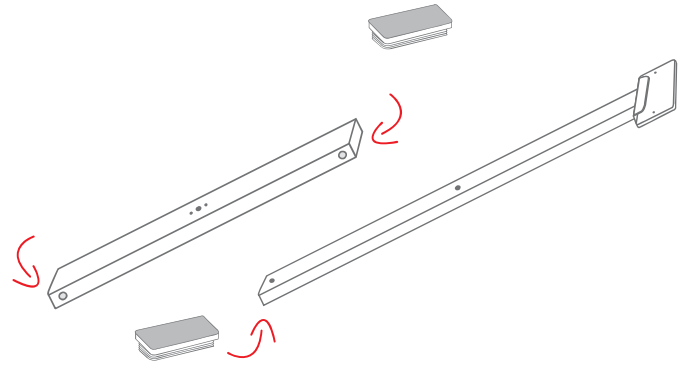

### STEP TWO

Screw the caster shafts (D) onto the caster bars (B), using a spanner to make sure that they are fully tightened.

Next attach the casters (E) to the shafts by pushing them on firmly.

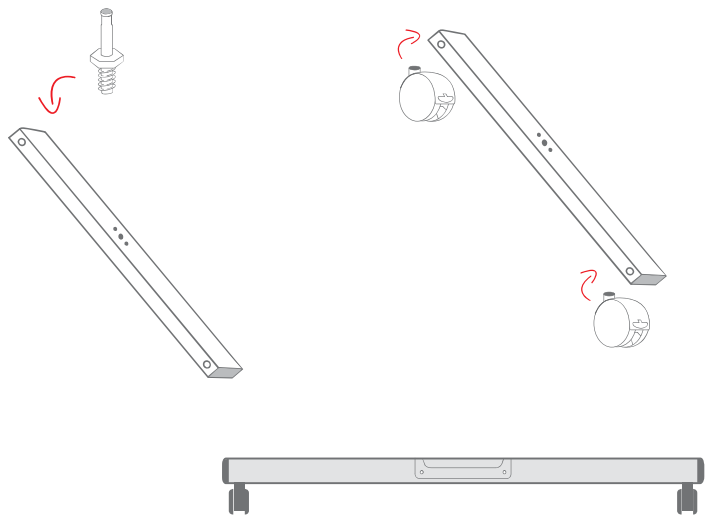

### STEP THREE

Align the holes of one of the upright members (C) with the holes of one of the caster bars (B), ensuring that the shorter side of the saddle is facing in towards the whiteboard.

Using the (F) 3mm allen key and the 4 x M5 16mm (G) bolts join uprights to the castor bars.

Repeat this process for the second upright and castor bar.

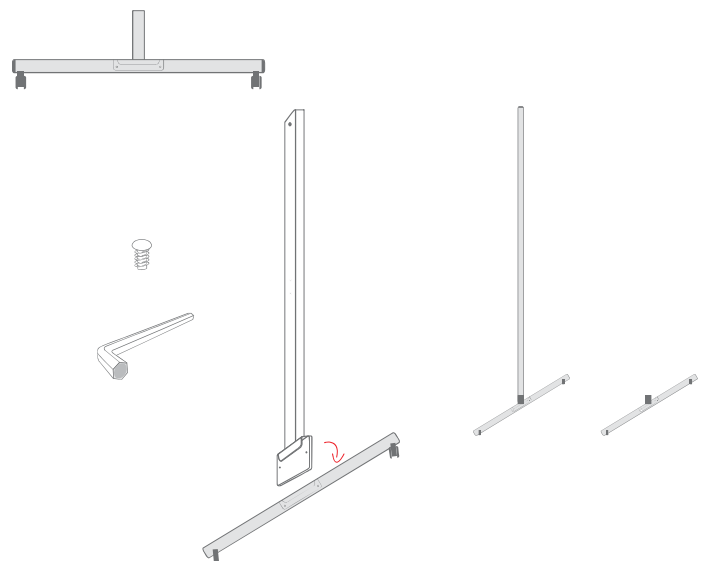

**...Create, Shape & Communicate**

[www.magiboardsusa.com](http://www.magiboardsusa.com) | (888) 393-7795 | [sales@magiboardsusa.com](mailto:sales@magiboardsusa.com)

# Magnetic Reversible Mobile Whiteboard

## ~ Assembly Instructions ~

### STEP FOUR

Using the (H) 5mm Allen key and the 2 x M8 50mm bolts (I) join the (J) lower cross member to both uprights / castor bars making sure the shorter side of the upright saddle is on the inside.

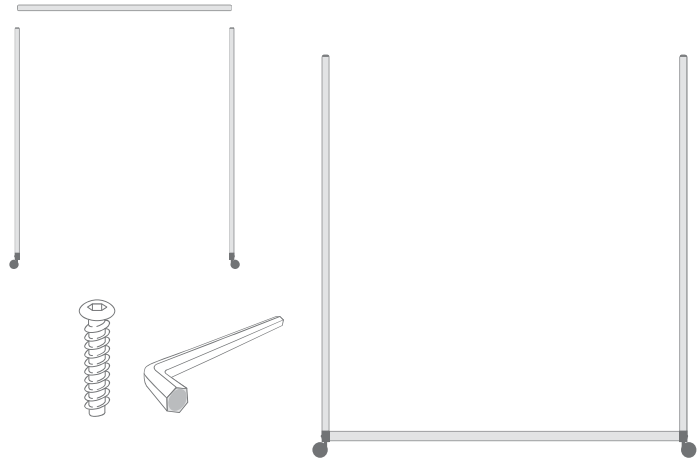

### STEP FIVE

Using the remaining 2 x M8 50mm bolts (I) to loosely join upper (K) cross member to stand.

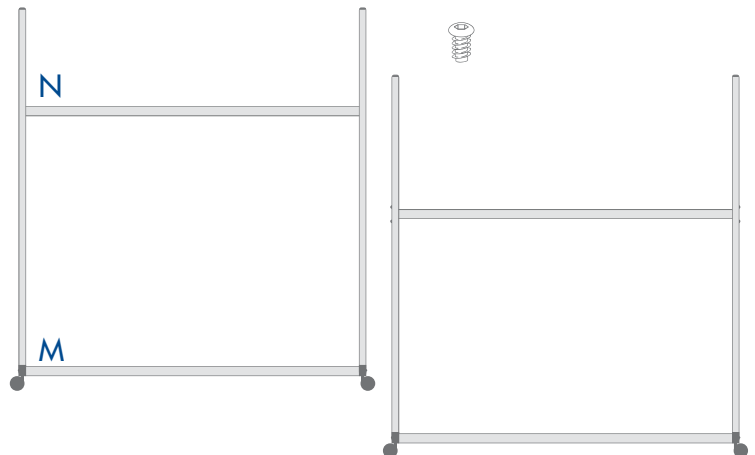

### STEP SIX

Align the holes of one side of the board with the holes on the swivel mechanism (L) and secure together using the M5 16mm bolts (G) and tighten with the 3mm allen key (F). Repeat this process on the other side of the board.

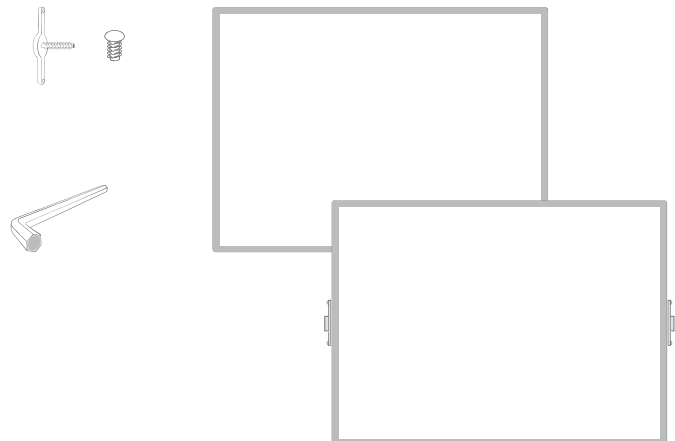

**...Create, Shape & Communicate**

# Magnetic Reversible Mobile Whiteboard

## ~ Assembly Instructions ~

**STEP SEVEN**

Place the rubber washers (M) over the threads of the board swivel mechanism (L). Next pick up the board and slot it into place at the top of the uprights (C).

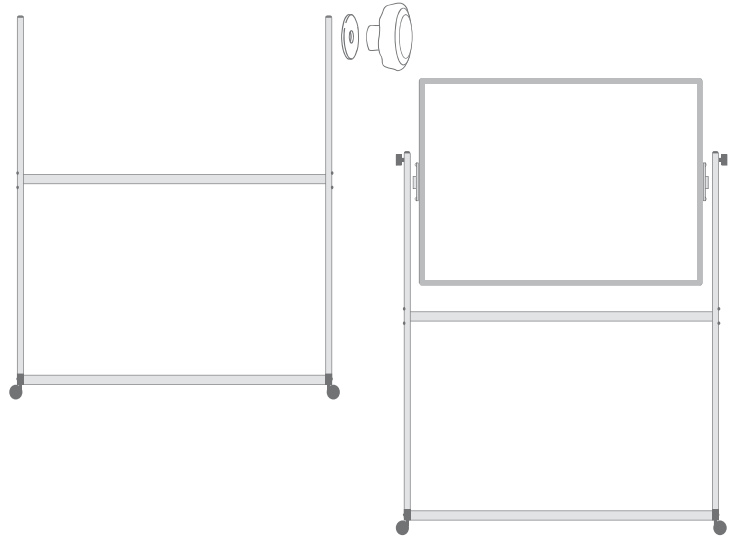

**STEP EIGHT**

Fasten by tightening the locking handle (N) on to the threaded end of the swivel mechanism. Tighten the bolts in the upper cross member (K) with the allen key (H).

Your Magiboards mobile stand is now ready to use.

Occasionally check bolts and screws for tightness. The mobile stand instructions are available at [www.magiboardsUSA.com](http://www.magiboardsUSA.com)

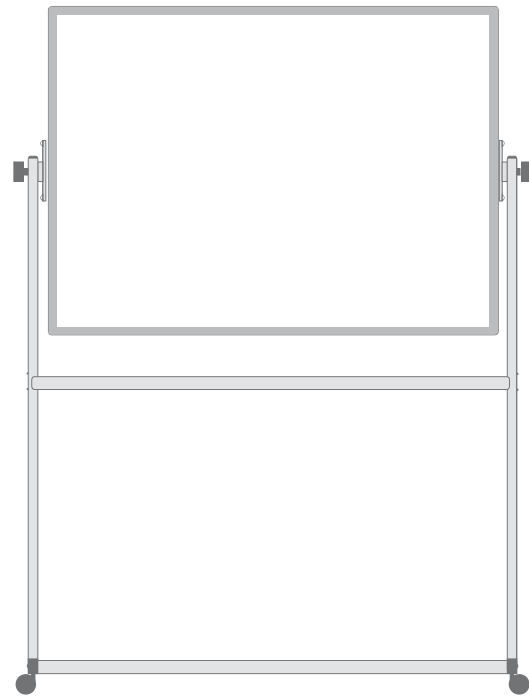

### THE MOBILE STAND RANGE

3ft x 4ft	4ft x 3ft	4ft x 4ft	5ft x 4ft	6ft x 4ft	8ft x 4ft

*...Create, Shape & Communicate*

[www.magiboardsusa.com](http://www.magiboardsusa.com) | (888) 393-7795 | [sales@magiboardsusa.com](mailto:sales@magiboardsusa.com)

# Magnetic Reversible Mobile Whiteboard ~ Assembly Instructions ~

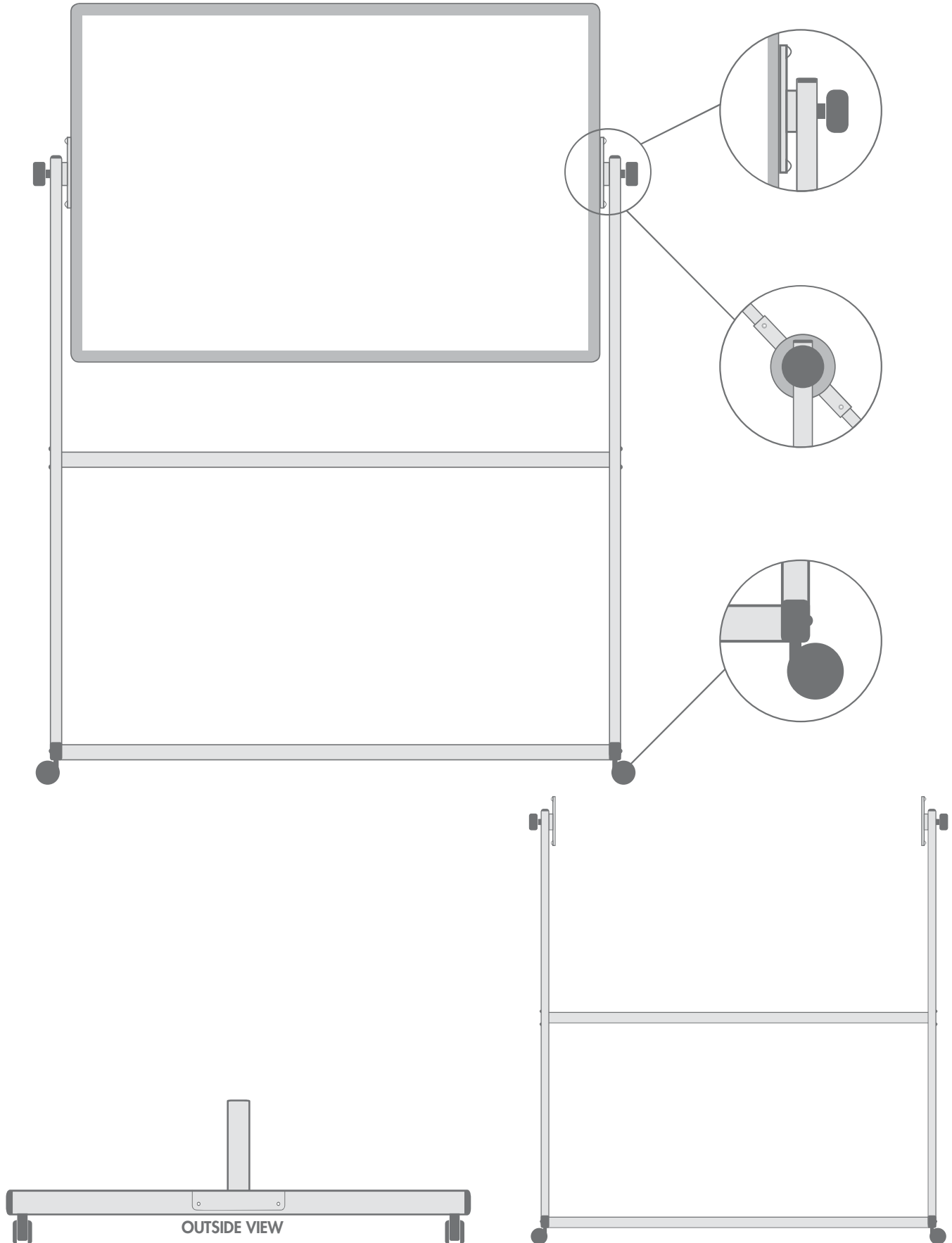

*...Create, Shape & Communicate*

[www.magiboardsusa.com](http://www.magiboardsusa.com) | (888) 393-7795 | [sales@magiboardsusa.com](mailto:sales@magiboardsusa.com)