







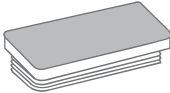

# Mobile Wingboard ~ Assembly Instructions ~

## What you will have:

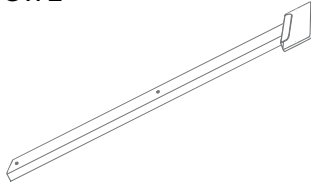
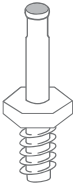
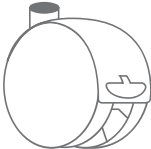
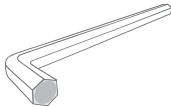
6 x End caps	A
2 x Caster Bar	B
2 x Uprights	C
4 x Caster Shafts	D
4 x Casters	E
1 x 3mm Allen Key	F
8 x M5 16mm Bolts	G
1 x 5mm Allen Key	H
4 x M8 Bolts 50MM	I
2 x Cross Members	J + K
2 x Mounting Bracket Sets	L

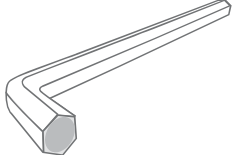
## Finished Product:

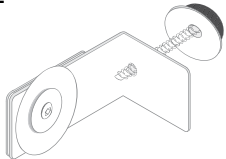

A x 6 	B x 2 	C x 2 	D x 4 
E x 4 	F x 1 	G x 8 	H x 1 
I x 4 	J x 1 	K x 1 	L x 2 

Before you use your new whiteboard for the first time make sure you clean all the panels thoroughly.  
If you have any further enquiries on how to fit your whiteboard please contact our customer service team.

# Mobile Wingboard ~ Assembly Instructions ~

## STEP ONE

Fit 4 of the end caps (A) on to both ends of the caster bars (B), fit the last two remaining end caps on to the open ends of the upright members (C). Tap the end caps on with a mallet to ensure they are fully inserted.

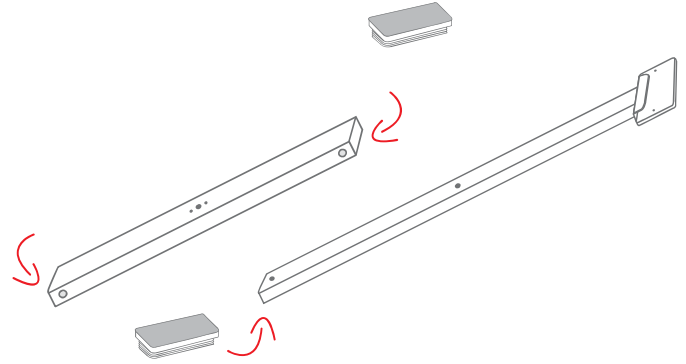

## STEP TWO

Screw the caster shafts (D) onto the caster bars (B), using a spanner to make sure that they are fully tightened.

Next attach the casters (E) to the shafts by pushing them on firmly.

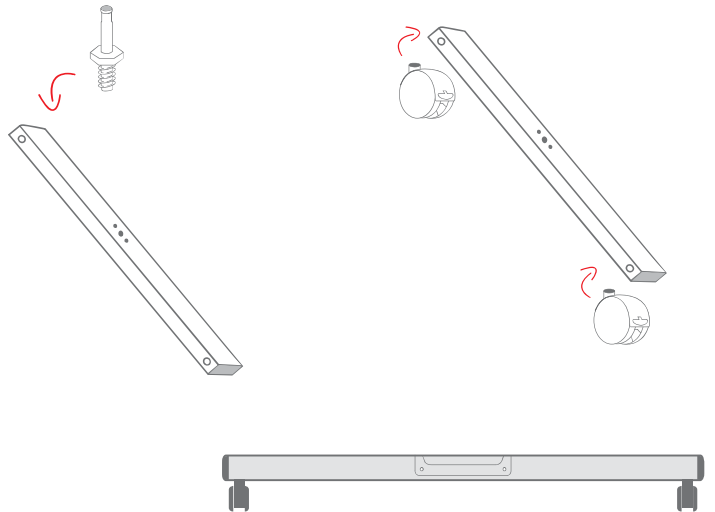

## STEP THREE

Align the holes of one of the upright members (C) with the holes of one of the caster bars (B), ensuring that the shorter side of the saddle is facing in towards the whiteboard.

Using the (F) 3mm allen key and the 4 x M5 16mm (G) bolts join uprights to the castor bars.

Repeat this process for the second upright and caster bar.

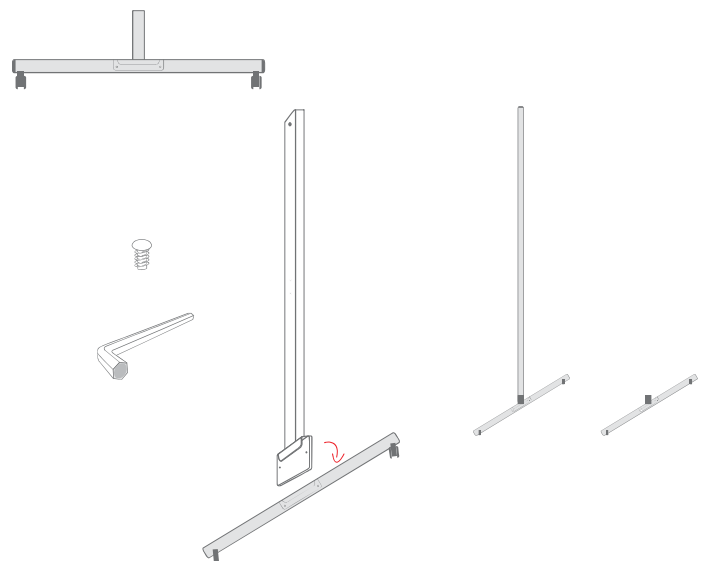

**...Create, Shape & Communicate**

[www.magiboardsusa.com](http://www.magiboardsusa.com) | (888) 393-7795 | [sales@magiboardsusa.com](mailto:sales@magiboardsusa.com)

# Mobile Wingboard ~ Assembly Instructions ~

## STEP FOUR

Using the (H) 5mm Allen key and the 2 x M8 50mm bolts (I) join the (J) lower cross member to both uprights / castor bars making sure the shorter side of the upright saddle is on the inside.

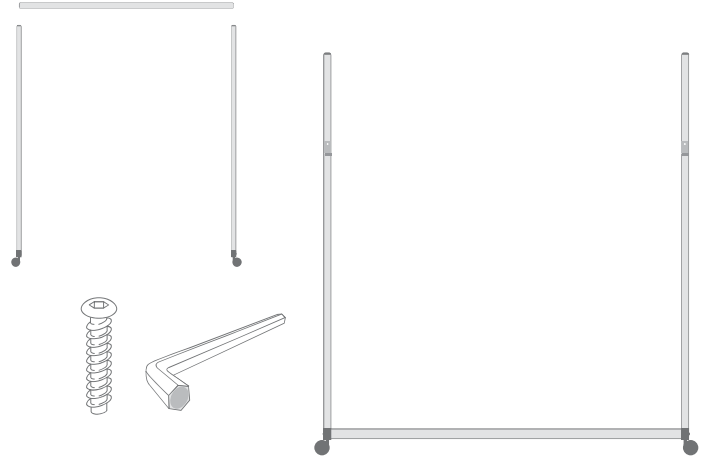

## STEP FIVE

Using the remaining 2 x M8 50mm bolts (I) to loosely join upper (K) cross member to stand.

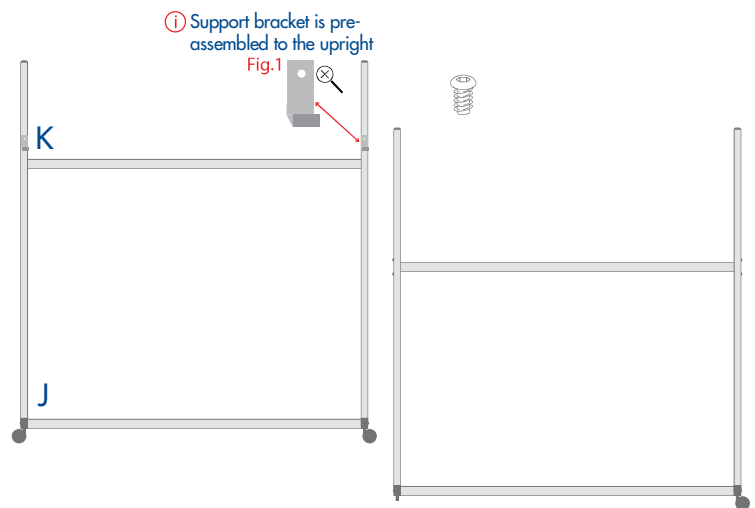

## STEP SIX

Unscrew the back plate of the mounting bracket set (L) and slide it into the right end of the lip channel on the back of the board. Loosely assemble the M8 socket button head with the washer back on to the back plate (you will tighten this in Step 8 on the instructions). Using the other mounting bracket set, repeat this process to attach to the left end of the lip channel.

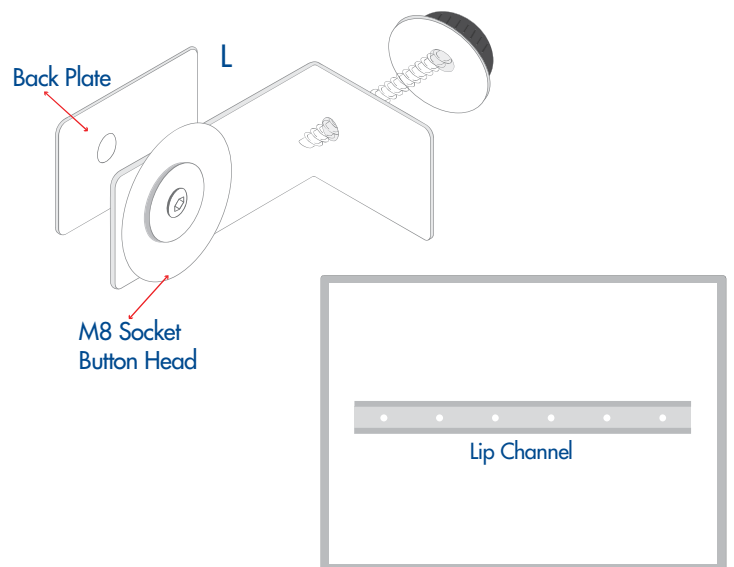

**...Create, Shape & Communicate**

# Mobile Wingboard ~ Assembly Instructions ~

## STEP SEVEN

Lift the board on to the two supporting brackets pre assembled to the uprights (see Fig 1 on page 3 for reference). Holding the board in place, remove the turnscrew from the mounting bracket set. Slide the screw through the hole on the upright so that it threads back on to the mounting bracket set and tighten. Repeat at the other end of the board.

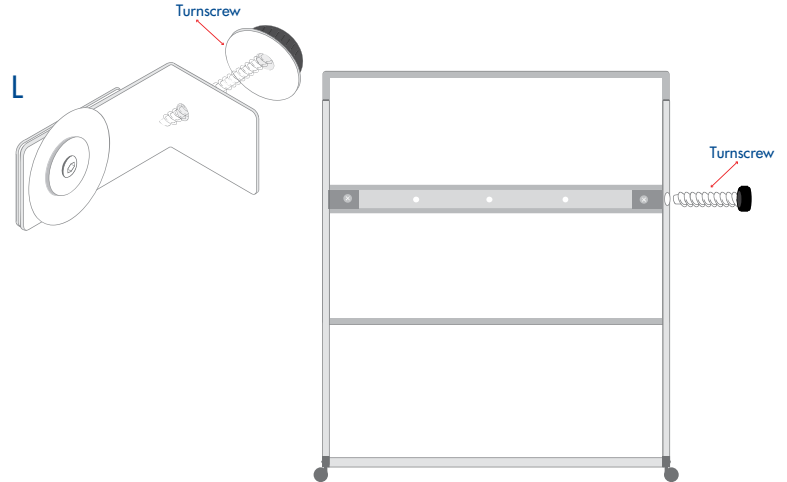

## STEP EIGHT

Finally, tighten the M8 Button Head Bolts securing the mounting bracket set to the lipped channel on the back of the board using the 5mm allen key (H).

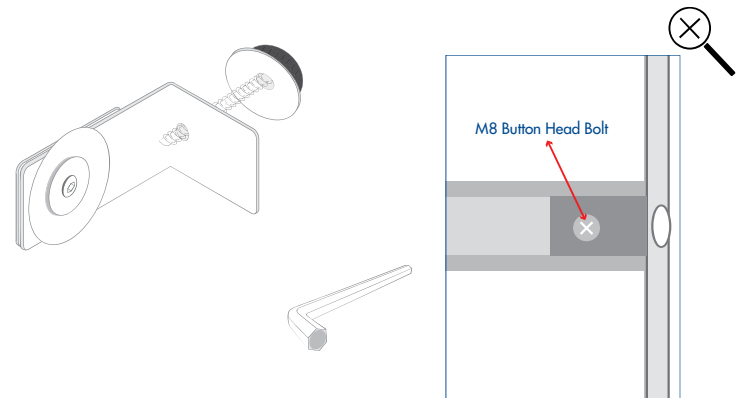

Your Magiboards mobile wingboard is now ready to use.

Occasionally check bolts and screws for tightness.

The mobile stand instructions are available at [www.magiboardsusa.com](http://www.magiboardsusa.com)

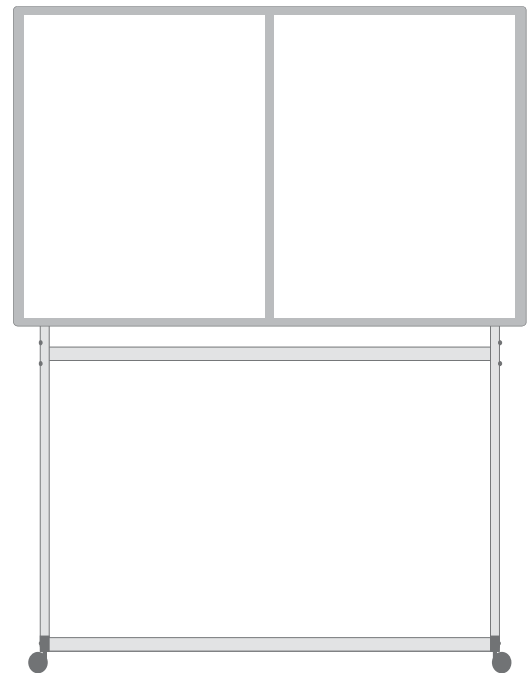

**...Create, Shape & Communicate**

[www.magiboardsusa.com](http://www.magiboardsusa.com) | (888) 393-7795 | [sales@magiboardsusa.com](mailto:sales@magiboardsusa.com)