

Visual Management Tools ■ Whiteboards ■ Tack Boards ■ Custom Solutions



Lean Visual Management Solutions



USA Manufacturer of Whiteboards & Notice Boards



www.magiboardsusa.com

sales@magiboardsusa.com | (888) 393-7795



Your Visual Management Partner



Founded in 1966, Magiboards is a proven manufacturer of whiteboards, custom printed whiteboards and lean visual industrial stands.

Now manufactured in Broomall, PA to the exacting standards in place in the UK

Lean visual management boards are vital to allow you to fully implement your Continuous Improvement (CI) project and fully engage the knowledge and experience of the people involved in the process.

You may be at the start of your lean journey or you may be introducing new methodologies.

Magiboards understands that different board solutions will be necessary for different stages and companies. That is why we have shown the various development phases of visual management boards and how to build your whiteboard to suit you.

See page 12.

Implementing your continuous improvement plan is one thing, but we all know that sustaining the improvement is the most challenging. That is why we recommend the use of whiteboards over digital solutions in areas where the buy-in of experts reacting with the process on a daily basis will ensure the ongoing success of the project. It is the experts on the shop floor who will drive through the change. Let them take control of the visual control systems.

As a manufacturer, we can produce standard and custom solutions. We manufacture everything from wall mounted whiteboards to full Obeya rooms and everything in between!

It is of course often the CI board accessories which bring the boards to life. We offer the full range of document holders, magnetic indicators, custom printed magnets and headers to make your project a success.

Finally our in-house graphic design team will work with you tirelessly producing to scale PDFs of your designs before production, helping you to develop the visual management products you need to run your business more effectively and profitably.



FACT People process visuals up to 60,000 times faster than text. We remember on average 20% of what we read and 37% of visual images we see. Visuals often immediately provide the context that we otherwise need to provide with text. Visuals bring a concept to life. Project planning involves planning of the time dimension, interrelationships between tasks, priorities, objectives, deadlines, bottlenecks, etc., all of which become clear in an instant if made visual. We immediately associate the use of the color red, exclamation points and traffic lights with urgency, risk, danger and attention.

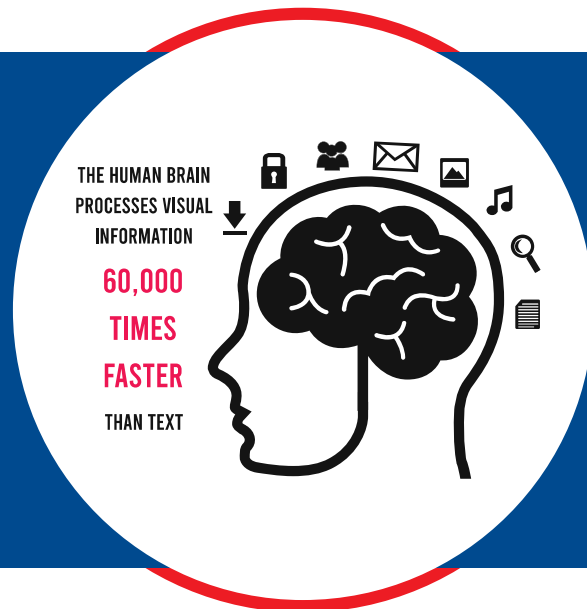

Here's why you should choose Magiboards:

We are a proven manufacturer of whiteboards, custom printed whiteboards and lean visual industrial stands.

We understand the need for you to develop your visual management systems. We offer a variety of product options from testing to implementation to replacement.

Our in-house graphic designers will work with your team, supplying visuals to scale with size dimensions and everything you need to reassure you that your design will work.

Years of experience working with CI professionals and vast galleries of examples to share with you.

Information

Introduction

About us	2
Why choose Magiboards	3
Case Study	16
Magiboards Locations	51

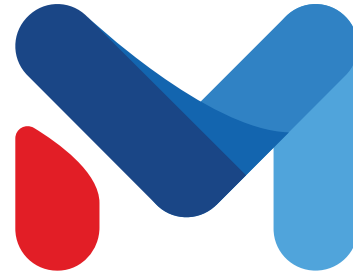

Information on Lean Boards

SQDC Whiteboard	6
Root Cause Analysis Whiteboards	7
5S Whiteboard	8
Continuous Improvement Whiteboard	9
Production SIC Whiteboard	10
Health, Safety & Environment Whiteboard	11

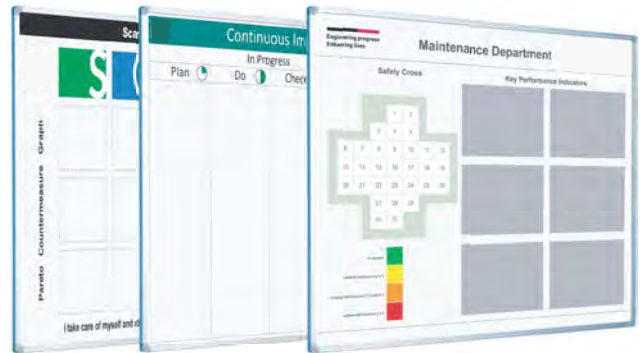

The Options to Create your Lean Boards

Printing Process & How to Order

Replacement Dye Sublimation Sheets

Icon key:



Manufactured in the USA



Custom sizes available



Rotates 360°



Magnetic surface



Dry Eraseable



Year surface guarantee



Coated steel surface

Products

Whiteboard

Wall Mounted Magnetic Whiteboards	17
Folding Whiteboards with Hinged Wings	18
Mobile Whiteboards with Stand	19
Folding Whiteboards with Hinged Wings on Stand	21
Rotating 3 & 4 Sided Whiteboards	22
Cube Whiteboards with Stands	25
Meeting Stations	29
Obeya Rooms & Lean Visual Corner	31
Large Whiteboards / Whiteboard Walls	32



Lean Whiteboard Accessories

Paper Holders	34
Magnetic Indicators	38
Magnetic Header Labels	41
Safety Cross & SQDC Trophy Magnets	41
General Whiteboard Accessories	42
T-card Panels	43
Gridding Tape	44
Mobile Stand Accessories	44
T Card System	45



SQDC Boards



SQDC is a daily process management tool for quickly providing a visual assessment of how the process is operating, based upon 4 main criteria: Safety, Quality, Delivery, Cost and often People & Environment (SQDCPE).



SQDC boards give an immediate visual of how an area is performing. You apply safe working practices with a key. For example, on the Safety Cross you could have **green** for No Incidents, **yellow** for a Near Miss or First Aid, **red** for Medical Treatment, Restricted Duty or Lost Time Injury and a **red** Exclamation point for Upcoming Test / Associated risks. It is also advisable to record incidents this month and this year and days since last recordable injury. Recordings can be made by using dry erase marker pens, colored magnetic squares, magnetic indicators or colored face magnets.



Color coordinated headings

Example SQDCPE board design

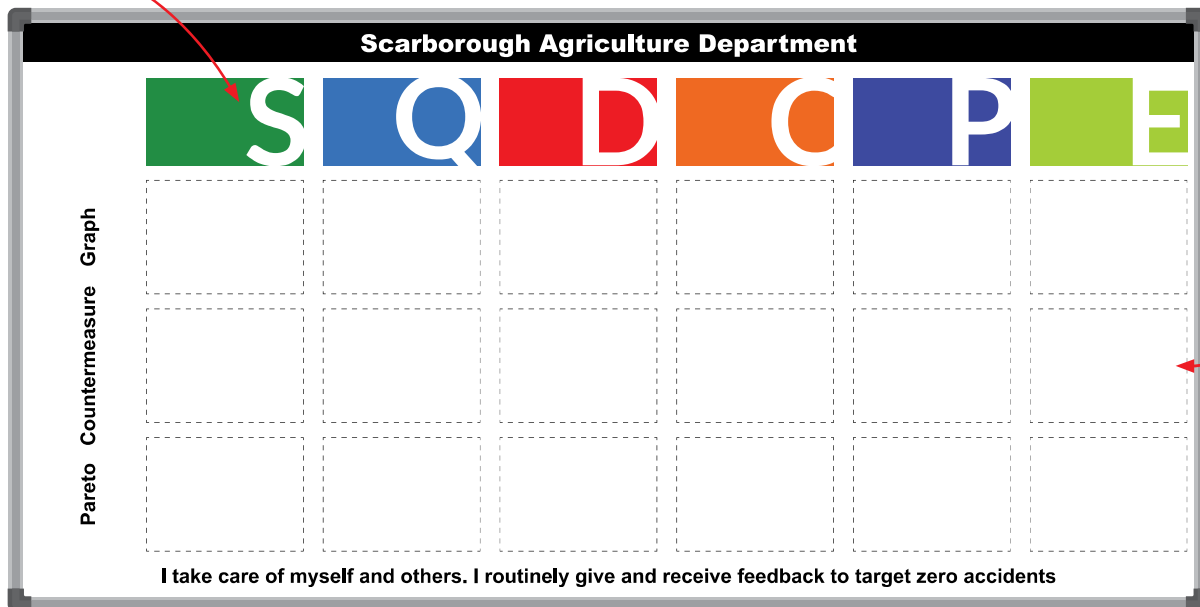

Root Cause Analysis Boards



Root Cause Analysis, such as 5 WHY, Cause and Effect diagrams, Fault Tree Analysis, Flowcharting, all aim to identify, analyse and implement corrective actions to solve a problem. The problem solving process is reviewed to understand the lessons learned in order to achieve further improvement within the business.

A **fishbone** diagram, also called a cause and effect diagram or **Ishikawa** diagram, is a visualisation tool for categorizing the potential causes of a problem in order to identify its root causes.

Also popular are the 5 WHY boards which identify the causes for a problem, identify a solution and estimate the saving to the business on the bottom line.

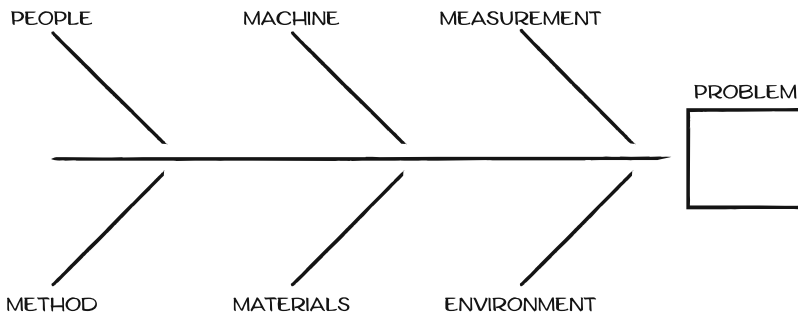

Example Root & Cause Analysis 5 WHYS board design

5 WHYS - OAKTHORPE					
DATE:	TEAM:	SHIFT:	DEPT:	AREA:	
What is the problem?			When does/old the problem occur?		
Who found the problem?			Why is it a problem?		
Where does the problem occur?			How does it affect us?		
Is there a temporary fix to put in place now?					
MAIN CAUSE OF PROBLEM?					
1st Why?	Reason for above		Reason for above		
2nd Why?	Reason for above		Reason for above		
3rd Why?	Reason for above		Reason for above		
4th Why?	Reason for above		Reason for above		
5th Why?	Reason for above		Reason for above		
Most effective solution(s) to root cause?	Action		Action		
	Responsible:	By Date:	Responsible:	By Date:	
5 Why status:	OPEN		ANALYSIS COMPLETE	CLOSED	
Sign Initials and date:	1 Why not yet completed or reviewed.		2 Why complete, correct still outstanding.	3 All analysis and actions complete.	

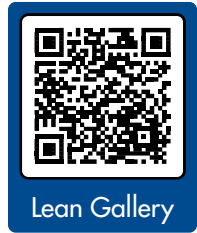

For Products, See Page 17

5S Boards



5S Boards consider the work area and its activity to determine where information, materials, tools and/or equipment are missing or require a new location and what improvements can be made to the area or activity. In short - A place for everything and everything in its place.



5S is a 5 step technique to stabilize, maintain and improve the best working equipment to support sustainable QCD (Quality, Cost, Delivery)
Sort, Set in order, Shine, Standardize, Sustain.



Example 5S board design

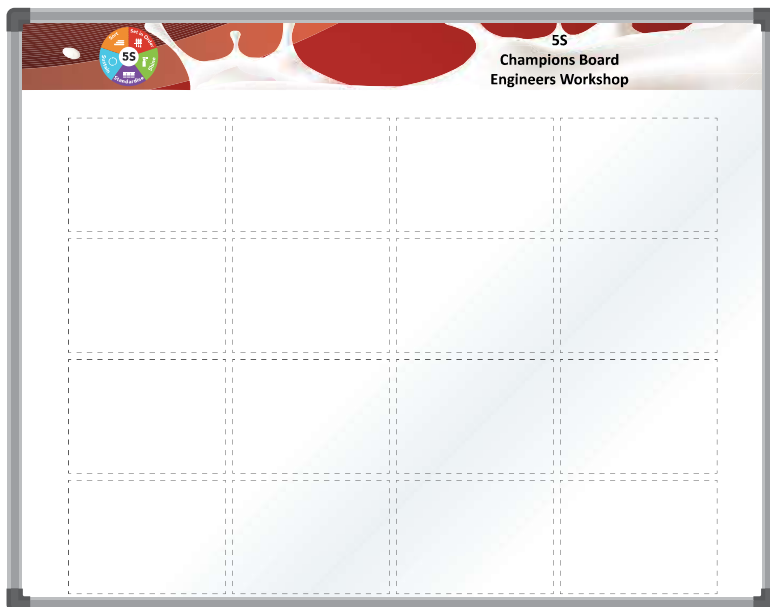

Continuous Improvement Boards



Kaizen Boards identify and confirm waste, problems or conditions within the work area or activity and what improvements can be made.

Plan the Kaizen process for the agreed area/activity to include Plan, Do, Check, Act + quantifiable objectives and targets for the improvement activity. This is known as the Deming Cycle.

The eight wastes (MUDA) are:
Over-Production, Inventory, Transport, Over-Processing, Waiting Time, Operator Motion, Bad Quality and failure to exploit human potential.

Activities which would give business benefits can be reduced product cost, increased capacity, improved safety, quality, compliance, customer service, reduction in lead time and elimination of waste.

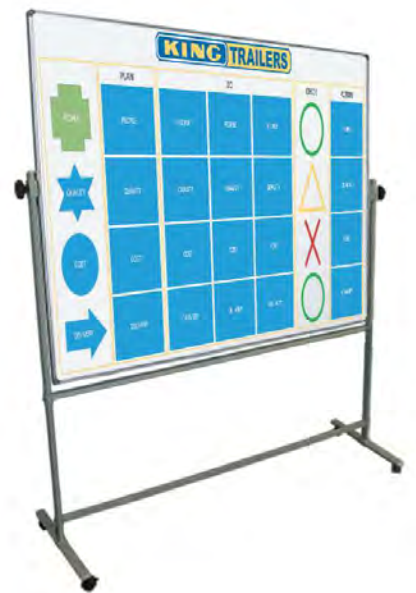

Example Deming Cycle board design

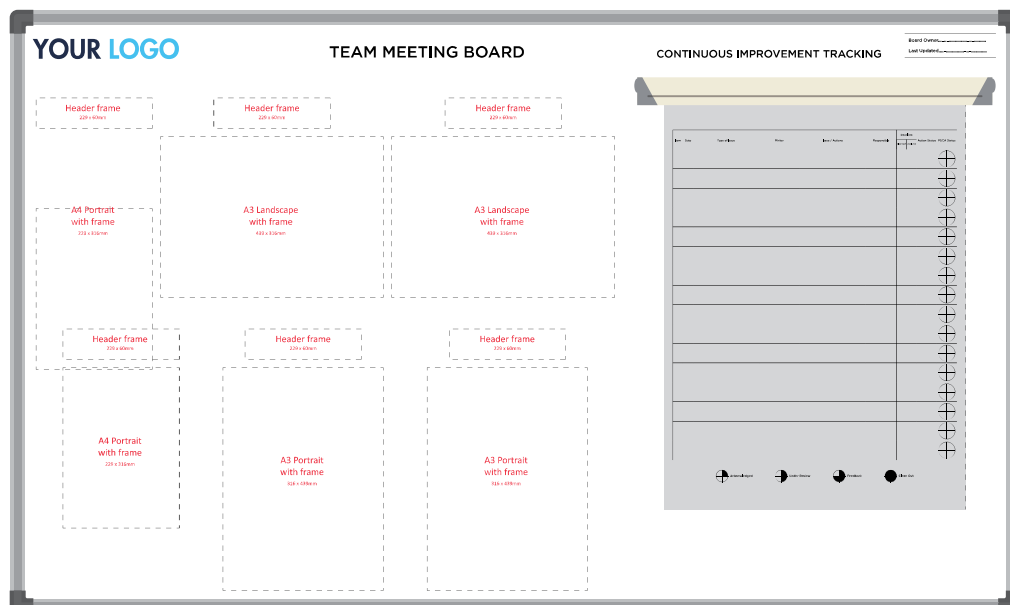

Production SIC Boards



Short Interval Control boards allow for quick and focused reviews of performance data during the shift which enable you to make mid-course corrections and immediate small-scale fixes that collectively result in significant improvements in performance.



Short Interval Control (SIC) is a structured process for identifying and acting on opportunities to improve the effectiveness and efficiency of production. It is a factory-floor process that engages team members to review performance data three or four times within their shift to assess where they need to focus their efforts to improve performance.

A key feature of SIC is the use of real-time production data to guide instantaneous front-line decision making. Teams are trained to collect, analyze, and react to this data in order to drive significant performance improvement from the factory floor.



Example Production SIC board design

Can Line Hourly SIC Board											
Time	Product	Can Size	Filler Standard Run Rate (CPS)	Hourly Target (CPS) from Sheet 2	Actual CPS	% OEE Achieved *Plant Status	Downtime Top 3's	Action Taken to Improve Next Hour	From Initial	To Initial	Feedback / Close Out
06:00											
07:00											
08:00											
09:00											
10:00											
11:00											
12:00											
13:00											
14:00											
15:00											
16:00											
17:00											
18:00											
19:00											
20:00											
21:00											
22:00											
23:00											
24:00											
00:00											
01:00											
02:00											
03:00											
04:00											
05:00											
06:00											

Quality	Can Size (ml)	Current SKU Volume
Filler Standard Run Speed	100% Run Speed Output	Current SKU Run Time Hrs Mins
Target HL/HR	Target Cans/HR	OEE/EFF Target

Health, Safety and Environment Boards



Many companies like to have a specific **Health and Safety** in addition to the usual SQDC board.

Health & Safety Notice Boards can include notices on Health & Safety Policy, Site Rules, Insurance Policies, First Aid Information, Permits and Inductions. This is very much led by the Health and Safety Officer.



THIS MONTH	THIS YEAR	1	2	We're Thinking and Working SAFELY Every Day™			
		3	4				
DAYS SINCE LAST RECORDABLE INJURY		5	6				
		7	8				
9	10	11	12	13	14	15	16
17	18	19	20	21	22	23	24
		25	26	No Incidents	[Green Box]		
		27	28	Near Miss or First Aid	[Yellow Box]		
		29	30	Medical Treatment, Restricted Duty or Lost Time Injury	[Red Box]		
		31		Upcoming Tests / Associated Risks	[Warning Sign]		

Example Health, Safety and Environment board design

Safety crosses play a pivotal role on Health & Safety boards. We can supply a safety cross or any custom design on a dry erase magnetic sheet with a magnetic backing, to offer you the option of a removable magnetic safety cross, usable with magnets and dry erase whiteboard marker pens.

This is a great option for creating a flexible working or test phase visual management board. See page 41.

ENVIRONMENTAL HEALTH & SAFETY MANAGEMENT BOARD									
ACCIDENTS/INCIDENTS	PERFORMANCE - MONTH / YTD	RISK ASSESSMENTS / COSHH / ISO PLAN & REGISTER	OUR AREA ACTIONS						
			DATE RAISED	RAISED BY	CONCERN / ISSUE	CORRECTIVE ACTION	WHO	WHEN	STATUS
THEME OF THE MONTH	[Safety Crosses]	WFF (DAILY)	SHORT TERM						
			DATE RAISED	RAISED BY	CONCERN / ISSUE	CORRECTIVE ACTION	WHO	WHEN	STATUS
FIRST AID	ZONE LAYOUT	MEETING MINUTES	LONG TERM						
			DATE RAISED	RAISED BY	CONCERN / ISSUE	CORRECTIVE ACTION	WHO	WHEN	STATUS

The Options to Create your Lean Boards



Maximum Impact

↳ Fully Custom Printed Whiteboard

You and your team have decided on a design for your lean whiteboard. Based on your mock up, Magiboards will optimize your design graphically and come back with a digital proof for your team to discuss, amend and ultimately approve.

Benefits

- + Fully custom printed whiteboard gives a totally professional finish
- + Totally smooth surface with no overlays - Ideal for the food industry
- + Designed by you in partnership with our in-house design team
- + Can be updated with replacement sheets. See below.

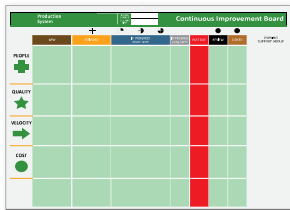
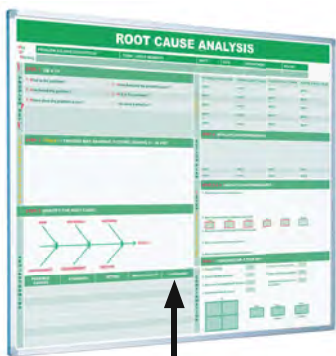

Need to change a board?

↳ Replacement Whiteboard Sheets

Your processes, methods and organisation will improve continuously and with that your Visual Management Tools will need to be updated. We offer a newly designed printed whiteboard sheet, complete with a magnetic backing, which simply sits on top of the old one. This will save costs, while retaining the same high quality Visual Management Boards.

Benefits

- + Cost effective method of creating a new custom printed whiteboard
- + Easy to attach and remove from your current whiteboard
- + Fully custom printed whiteboard solution
- + No need to throw away boards or stands
- + Allows you to continuously move forward





Uniformity with Flexibility

↳ Custom Printed Header Boards

Global companies may have different size factories with different needs. The header boards allow you to set a standard across all divisions. Use magnetic headers and accessories to create your own boards. Magiboards can help you design and will supply all your magnetic accessories.

Benefits

- + Gain cost savings on larger print runs which can then be tailored to individual needs
- + Headers available with dye sublimation or magnetic backed vinyl
- + Full range of standard & custom accessories available



Early Stages & Fluid Processes

↳ Plain Boards & Accessories

In the earliest stages of your Lean journey your Visual Management tools may be very fluid. If that is the case, why not start with a blank canvas using the various tools Magiboards can offer to create a fully flexible Visual Management board. Magiboards can offer a wide range of magnetic headers, document holders, charting and magnetic tape, magnetic indicators etc.. to help you set up and test your design. Once your design is finalized, you can order a replacement whiteboard sheet which will sit snugly over the plain board without the need to remove the board from the wall or replace expensive mobile stands.

Benefits

- + Create your own totally customizable whiteboard
- + Low cost custom whiteboard solution
- + Experiment with new board layouts / designs at minimal cost by using Magiboards accessories

Our Printing Process & How to Order

Our Printing Process

We use a process known as 'dye sublimation printing'. Dye sublimation printing is a process whereby a negative of the image is printed on special transfer paper. The ink is then heated to a gas in a heat transfer press and absorbed into the surface of the magnetic dry erase whiteboard. The graphics are embedded in the whiteboard. This gives huge benefits over other printing methods, such as:

- **High quality print**
- **Totally smooth, clean surface**
- **Easy to keep clean and offers a longer life span**
- **Significant quantity discounts available**
- **No vinyl overlays - Ideal for food manufacturers, hospitals and other environments where cleanliness and reducing the risk of germs is high priority**

How to Order a Custom Printed Whiteboard

Creating and ordering your own custom printed whiteboard has never been easier! We've created this simple 4-step guide as a path through the process. With high quality print, a 10 year surface guarantee there's never been a better time to create your own custom printed magnetic whiteboard,

STEP 01

Simply send us the size board you require and quantity, along with a brief description / sketch / mock up of your design

STEP 02

You will receive a quotation for your order, including artwork generation, digital proofing and the cost of delivery

STEP 03

Having approved the quote and placed your order, we will then create your artwork and send you a digital proof for approval or revisions. There are no additional costs at this stage

STEP 04

Upon approval of the digital proof, your order will go to production. There is a lead time of 3 - 4 weeks from sign off of the digital proof. **Get ready for delivery!**

Replacement Whiteboard Sheets

How does it work?

The lean journey demands **change for the better**. As your lean partner, we understand this. That is why we offer a replacement magnetic whiteboard sheet which can sit neatly over your whiteboard.

- Update your graphics with little effort
- The magnetic backing simply mounts over your existing Magiboard in seconds
- No drilling or stress
- Avoid waste

What is the Replacement Sheet made from?

- A magnetic sheeting
- Vinyl laminated to the magnetic sheet and printed with the new layout
- A clear dry erase film laminated over the printed vinyl

The Benefits

- Cost effective solution for updating your custom printed whiteboard
- Totally smooth, easy to clean surface
- Accepts magnetic accessories
- Excellent dry erase surface
- Clear and long lasting print
- Quantity discounts available on larger runs

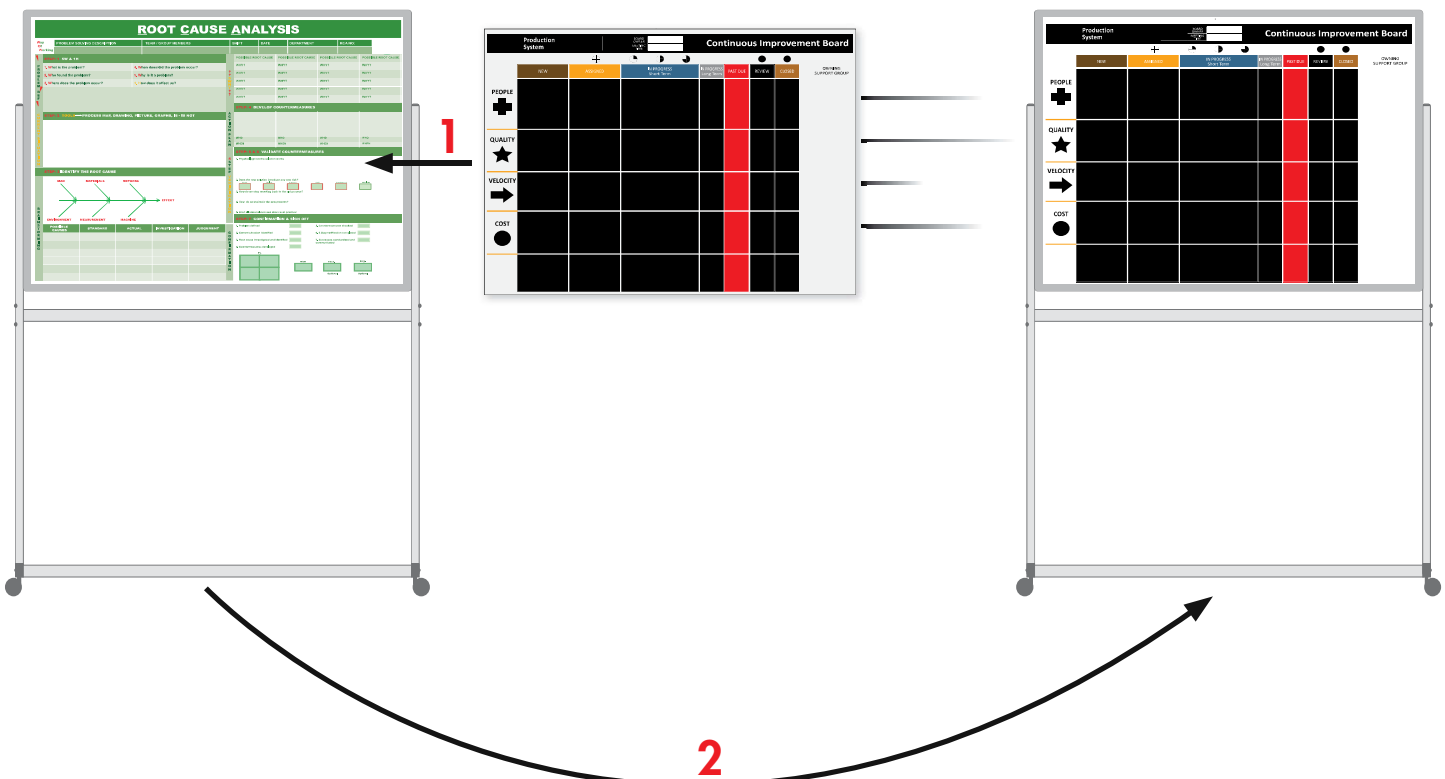

Case Study

Element Materials Technology element

Element Materials Technology is one of the fastest growing companies in the global Testing, Inspection & Certification sector. Element is active in over 30 countries and has nearly 200 laboratories.

Stage 1: Trial Period

Magiboards works with one UK site to produce a range of custom printed whiteboards for the CI department. Artworks are created and signed off prior to production.

Stage 2: Roll out in UK and Europe

The range of designs and accessories is extended. Magiboards creates a custom area on their website where any facility can register and then access their products to buy online. Stocks are held at Magiboards for order fulfilment.

- **Uniformity of design**
- **Economies of scale**
- **Ownership by each local site**
- **Easy management overview of development of Continuous Improvement plan through the company**

Stage 3: Roll out to USA, Canada and ROW

Magiboards sets up joint venture in the US with a manufacturing partner, creating a Magiboards USA website and stock products for local shipment and purchase in US dollars.

- **Improved customer service levels**
- **Reduction in lead times**

What have we learned?

A global company may have many different size plants with different needs. A flexible approach is required without compromising on quality. The larger sites have room for larger boards. These can be fully printed in quantities and have top quality with economies of scale.

For smaller sites we adopted a more flexible approach with the introduction of small size multi-purpose boards which use different magnetic printed headers and accessories to create multiple outcomes.

Flexible working boards mean that economies of print run are still available and global guidelines are still followed. As both companies move forward in the process, we are creating magnetic back dye sublimation sheets which can sit on top of existing boards without the need to replace boards or have new stands.

Magiboards acts as a partner to us in our Lean journey. They are responsive when we need new designs and effective in helping us define the appropriate supply chain to delivery the right products to Element sites.

Christiaan Verhoeven
Group Operations Excellence Director
Element Materials Technology



Wall Mounted Whiteboard Solutions



COATED
STEEL



Available with a magnetic coated steel surface, wall mounted magnetic whiteboards are an essential tool in any office, manufacturing or lean environment. With the choice of 6 standard sizes or the option of a made-to-measure board as well as a choice of single or double sided, we're sure our range configurations will meet your specification.

Features

- Dry erase surface which accepts magnetic accessories
- Choice of a single or double sided whiteboard
- Standard sizes & custom sizes available
- Can be wall mounted in landscape or portrait orientation



Custom Printed Dye Sublimation Whiteboard



Custom Printed Header Whiteboard



Plain Magnetic Whiteboard

Size (feet)	Plain	Printed
4ft x 3ft	SAP4836	SA4836
4ft x 4ft	SAP4848	SA4848
5ft x 4ft	SAP6048	SA6048
6ft x 4ft	SAP7248	SA7248
8ft x 4ft	SAP9648	SA9648



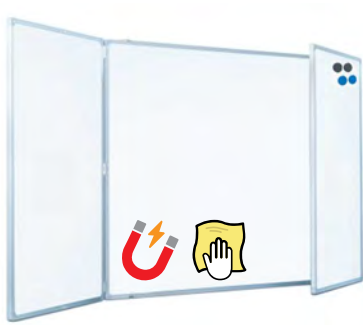

2 Wing Whiteboard

Folding Whiteboards with Hinged Wings



Folding whiteboards are ideal for use in areas which are tight on space, or in areas where you may need to temporarily hide sensitive information from public view. Our range includes whiteboards with 1 or 2 wing configuration with a coated steel surface. This product is also available on a mobile stand with a 2 wing configuration, [see page 21](#).

FEATURES

- Dry erase surface which accepts magnetic accessories
- Choice of 1 or 2 wing configurations
- Small discreet magnets keep the wing in place when closed
- Standard sizes & custom sizes available
- Sizes quoted are with the wings closed
- 1 Foot wide mini wings are also available

Example size diagram

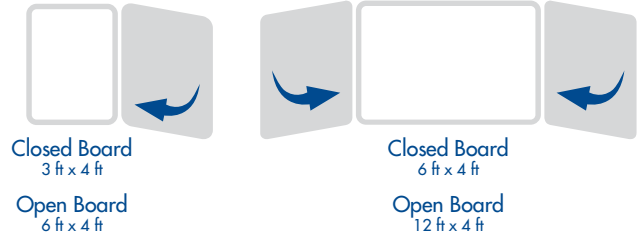

Custom Printed Dye Sublimation Whiteboard



Custom Printed Header Whiteboard



Plain Magnetic Whiteboard

Size (feet)	Wings	Plain	Central Panel Printed	Central & Inner Wings Printed	All Surfaces Printed
3' x 2'	1x Wing*	WB1P0-3624	WB1P1-3624	WB1P2-3624	WB1P3-3624
3' x 4'	1x Wing*	WB1P0-3648	WB1P1-3648	WB1P2-3648	WB1P3-3648
4' x 3'	2xWings	WB1P0-4836	WB1P1-4836	WB1P2-4836	WB1P3-4836
4' X 4'	2xWings	WB1P0-4848	WB1P1-4848	WB1P2-4848	WB1P3-4848
6' X 4'	2xWings	WB1P0-7248	WB1P1-7248	WB1P2-7248	WB1P3-7248

*Add (L) or (R) to SKU depending on where wing is attached Left or Right



Revolving Mobile Whiteboard with Stand



Our revolving mobile whiteboard is fitted to a sturdy mobile stand with lockable wheels and can be supplied as a single or double sided whiteboard. Mobile stand whiteboards offer you increased flexibility by way of allowing you to share a whiteboard with another office or work station, which can improve work flow and help collaborative projects.

Features

- Choice of a single or double sided mobile whiteboard
- The board rotates through 360 degrees
- Locking handle to fix the board firmly in place
- Supplied with non marking glide easy wheels, 2 of which are lockable
- Boards with 1 side print have a plain, magnetic, dry erase whiteboard on the reverse



Custom Printed Header Whiteboard



Custom Printed Dye Sublimation Whiteboard



Plain Magnetic Whiteboard

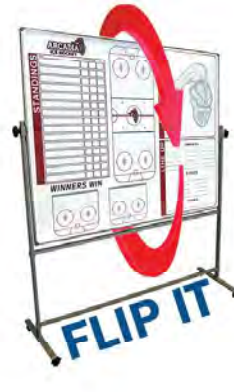

Size (feet)	Orientation	Plain 1 Sided	Plain/Plain	Print/Plain	Print 2 Sides
3' x 4'	Portrait	MB01-3648R	MB02-3648R	MB11-3648R	MB20-3648R
4' x 3'	Landscape	MB01-4836R	MB02-4836R	MB11-4836R	MB20-4836R
4' X 4'	n/a	MB01-4848R	MB02-4848R	MB11-4848R	MB20-4848R
5' X 4'	Landscape	MB01-6048R	MB02-6048R	MB11-6048R	MB20-6048R
6' X 4'	Landscape	MB01-7248R	MB02-7248R	MB11-7248R	MB20-7248R
8' X 4'	Landscape	MB01-9648R	MB02-9648R	MB11-9648R	MB20-9648R



Fixed Mobile Whiteboard with Stand



Our fixed mobile whiteboard is fitted to a sturdy mobile stand with lockable wheels. Unlike the revolving whiteboard, this whiteboard is fixed in place and ideal for double sided board designs, using Tabloid & Letter paper holders.

Features

- Choice of a single or double sided mobile whiteboard
- The whiteboard is fixed in place on the mobile stand
- Supplied with non marking glide easy wheels, 2 of which are lockable
- Custom sizes available
- Boards with 1 side print have a plain, magnetic, dry erase whiteboard on the reverse

Accessories for Mobile Stands



Heavy Duty Wheels

- Upgrade the casters to heavy duty wheels
- Assembled in factory

Configuration	Code
Heavy Duty Wheels	AM0004



Custom Printed Dye Sublimation Whiteboard



Custom Printed Header Whiteboard



Plain Magnetic Whiteboard

Size (feet)	Orientation	Plain 1 Sided	Plain/Plain	Print/Plain	Print 2 Sides
3' x 4'	Portrait	MB01-3648F	MB02-3648F	MB11-3648F	MB20-3648F
4' x 3'	Landscape	MB01-4836F	MB02-4836F	MB11-4836F	MB20-4836F
4' X 4'	n/a	MB01-4848F	MB02-4848F	MB11-4848F	MB20-4848F
5' X 4'	Landscape	MB01-6048F	MB02-6048F	MB11-6048F	MB20-6048F
6' X 4'	Landscape	MB01-7248F	MB02-7248F	MB11-7248F	MB20-7248F
8' X 4'	Landscape	MB01-9648F	MB02-9648F	MB11-9648F	MB20-9648F



Folding Whiteboard with Hinged Wings on Stand



Mobile whiteboards with hinged wings are supplied on a sturdy, mobile stand with lockable wheels. The addition of 2 centrally opening wings gives a total of **5 surfaces** to write on. The wing sizes are half the width of the board x the height of the board.

Features

- 2 Wing configurations with 5 whiteboard surfaces
- Dry erase surface which accepts magnetic accessories
- Small discreet magnets keep the wings in place when closed
- Standard sizes & custom sizes available
- Supplied with non marking glide easy wheels, 2 of which are lockable

Specification

Surface Type	Magnetic Coated Steel
Surface Guarantee	10 Year guarantee
Whiteboard Surfaces	5
Dry Eraseable	Yes
Wings	2
Frame	Aluminum
Height	6' 3"
Casters	4 x Casters (2 x Lockable)



Custom Printed Dye Sublimation Whiteboard



Custom Printed Header Whiteboard



Plain Magnetic Whiteboard

Size (feet)	Wings	Plain	Central Panel Printed	Central & Inner Wings Printed	All Surfaces Printed
4' x 3'	2xWings	MWC207L	MWSCP207C	MWSCP207W	MWSCP2072W
4' X 4'	2xWings	MWC208	MWSCP208C	MWSCP208W	MWSCP2082W
5' X 4'	2xWings	MWC209L	MWSCP209C	MWSCP209W	MWSCP2092W



Rotating 3 Sided Whiteboard with Stand



Our 3 sided whiteboard rotates through 360 degrees and is fitted to a sturdy central pole and flat base. Often referred to as a 'Huddle Board', these boards are ideal for information points and production environments. Each whiteboard side measures 2 ft x 4 ft, width x height.

Features

- 3 Sided whiteboard solution
- Each whiteboard measures 2 ft x 4 ft w x h
- The board rotates through 360 degrees
- Powder coated steel circular base, 2 ft in diameter
- Available with 5 x heavy duty wheels attached

Specification

Surface Type	Magnetic Coated Steel
Surface Guarantee	10 Year guarantee
Whiteboard Surfaces	3
Whiteboard Size	2 ft x 4 ft
Dry Eraseable	Yes
Rotation	360° Rotation
Frame	Aluminum
Height	6' 3"
Circular Base	2 ft diameter



Custom Printed Dye Sublimation Whiteboard



Custom Printed Header Whiteboard



Plain Magnetic Whiteboard

You Can Add Heavy Duty Wheels to your Rotating Whiteboards



Size / Base Configuration	Plain	Printed 1 Side	Printed 2 Sides	Printed 3 Sides
Midi / Flat Base	MCR001	MCPR101	MCPR201	MCPR301
Midi / Wheels Attached	MCR002W	MCPR101W	MCPR201W	MCPR301W

Rotating 4 Sided Whiteboard with Stand Midi



Our 4 sided whiteboard rotates through 360 degrees and is fitted to a sturdy central pole and flat base. Often referred to as a 'Huddle Board', these boards are ideal for information points and production environments. Each whiteboard side measures 2 ft x 4 ft, width x height.

Features

- 4 Sided whiteboard solution
- Each whiteboard measures 2 ft x 4 ft w x h
- The board rotates through 360 degrees
- Powder coated steel circular base, 2 ft in diameter
- Available with 5 x heavy duty wheels attached

Specification

Surface Type	Magnetic Coated Steel
Surface Guarantee	10 Year guarantee
Whiteboard Surfaces	4
Whiteboard Size	2 ft x 4 ft
Dry Eraseable	Yes
Rotation	360° Rotation
Frame	Aluminum
Height	6' 3"
Circular Base	2 ft diameter



Custom Printed Dye Sublimation Whiteboard



Custom Printed Header Whiteboard



Plain Magnetic Whiteboard

You Can Add Heavy Duty Wheels to your Rotating Whiteboards



Size / Base Configuration

Plain

Printed 1 Side

Printed 2 Sides

Printed 3 Sides

Printed 4 Sides

Midi / Flat Base

MCR004

MCPR104

MCPR204

MCPR304

MCPR404

Midi / Wheels Attached

MCR004W

MCPR104W

MCPR204W

MCPR304W

MCPR404W



Rotating 4 Sided Whiteboard with Stand Maxi



The Maxi version offers extra whiteboard space with each whiteboard side measuring 2 ft x 6 ft, width x height.

Features

- 4 Sided whiteboard solution
- Each whiteboard measures 2 ft x 6 ft w x h
- The board rotates through 360 degrees
- Powder coated steel circular base, 2 ft in diameter
- Available with 5 x heavy duty wheels attached

Specification

Surface Type	Magnetic Coated Steel
Surface Guarantee	10 Year guarantee
Whiteboard Surfaces	4
Whiteboard Size	2 ft x 6 ft
Dry Eraseable	Yes
Rotation	360° Rotation
Frame	Aluminum
Height	6' 3"
Circular Base	2 ft diameter



Custom Printed Dye Sublimation Whiteboard



Custom Printed Header Whiteboard



Plain Magnetic Whiteboard

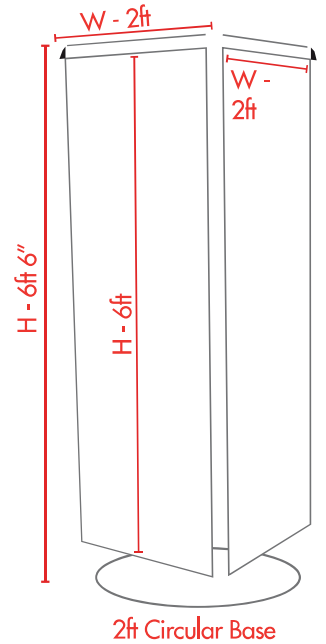

Size / Base Configuration

Plain

Printed 1 Side

Printed 2 Sides

Printed 3 Sides

Printed 4 Sides

Size / Base Configuration	Plain	Printed 1 Side	Printed 2 Sides	Printed 3 Sides	Printed 4 Sides
Maxi / Flat Base	MCRL04	MCRL14	MCRL24	MCRL34	MCRL44
Maxi / Wheels Attached	MCRL04W	MCRL14W	MCRL24W	MCRL34W	MCRL44W



Mobile Whiteboard Cube Midi



The mobile whiteboard cube is great for displaying key messages in the workplace. Each of the 4 sides is made from a magnetic coated steel dry erase whiteboard, which comes with a 10 year surface guarantee. Each whiteboard side measures 2 ft x 4 ft, width x height.

Features

- 4 Sided whiteboard solution
- Each whiteboard measures 2 ft x 4 ft w x h
- Supplied with 4 x heavy duty wheels, 2 are lockable
- Usable with magnetic accessories
- Also available with cabinet option, see page 27

Specification

Surface Type	Magnetic Coated Steel
Surface Guarantee	10 Year guarantee
Whiteboard Surfaces	4
Whiteboard Size	2 ft x 4 ft
Dry Eraseable	Yes
Frame	Aluminum 1 in x 1 in
Height	6' 3"
Casters	2 ft diameter



Custom Printed Dye Sublimation Whiteboard



Custom Printed Header Whiteboard



Plain Magnetic Whiteboard

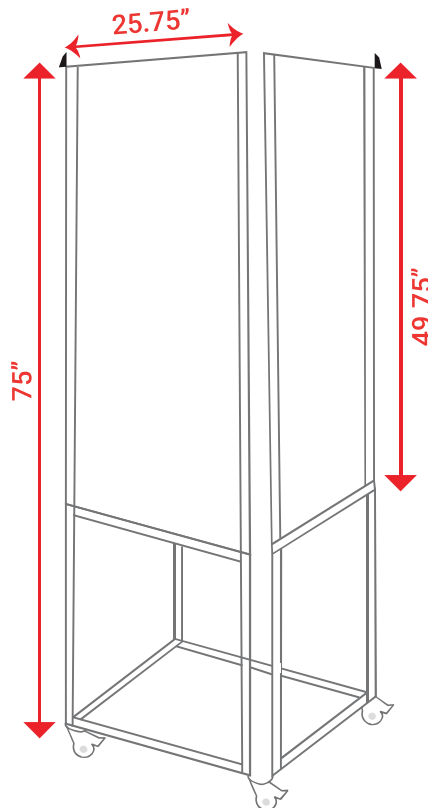

Size	Plain	Printed 1 Side	Printed 2 Sides	Printed 3 Sides	Printed 4 Sides
Midi	MCUBS001	MCUBSCP11	MCUBSCP21	MCUBSCP31	MCUBSCP41

Mobile Whiteboard Cube Maxi



The Maxi version offers extra whiteboard space with each whiteboard side measures 2 ft x 6 ft, width x height.

Features

- 4 Sided whiteboard solution
- Each whiteboard measures 2 ft x 6 ft w x h
- Supplied with 4 x heavy duty wheels, 2 are lockable
- Usable with magnetic accessories
- Also available with cabinet option, see page 28

Specification

Surface Type	Magnetic Coated Steel
Surface Guarantee	10 Year guarantee
Whiteboard Surfaces	4
Whiteboard Size	2 ft x 6 ft
Dry Eraseable	Yes
Frame	Aluminum 1 in x 1 in
Height	6' 3"
Casters	4 x Casters (2 x Lockable)



Custom Printed Dye Sublimation Whiteboard



Custom Printed Header Whiteboard

Plain Magnetic Whiteboard

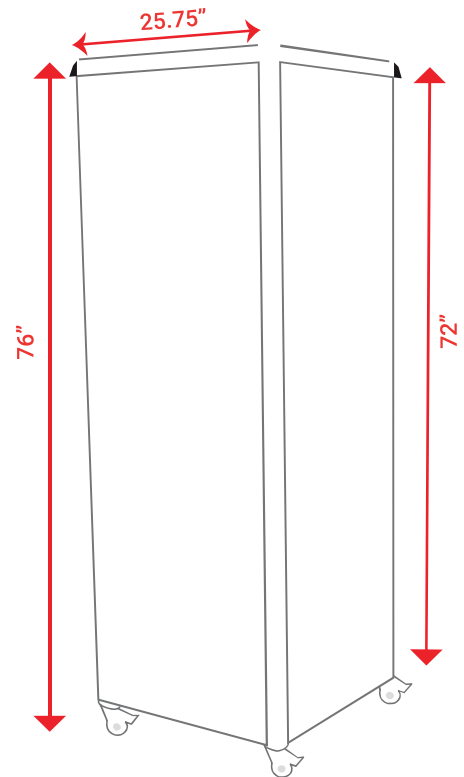

Size Plain Printed 1 Side Printed 2 Sides Printed 3 Sides Printed 4 Sides

Maxi MCUBE001 MCUBESCP11 MCUBESCP21 MCUBESCP31 MCUBESCP41

Mobile Whiteboard Cube Cabinet Midi



The mobile whiteboard cabinet is a great product for visual management on the factory floor or in offices. Each of the 4 sides is made from a quality magnetic coated steel dry erase whiteboard. Each whiteboard side measure 2 ft x 4 ft, width x height.

Features

- 4 Sided whiteboard solution
- Each whiteboard measures 2 ft x 4 ft w x h
- Supplied with 4 x heavy duty wheels, 2 are lockable
- Includes 2 shelves (including base)
- Usable with magnetic accessories
- Custom options available

Specification

Surface Type	Magnetic Coated Steel
Surface Guarantee	10 Year guarantee
Whiteboard Surfaces	4
Whiteboard Size	2 ft x 4 ft
Shelves	2 (including base)
Dry Eraseable	Yes
Frame	Aluminum 1 in x 1 in
Height	6' 3"
Casters	4 x Casters (2 x Lockable)



Custom Printed Dye Sublimation Whiteboard



Custom Printed Header Whiteboard



Plain Magnetic Whiteboard

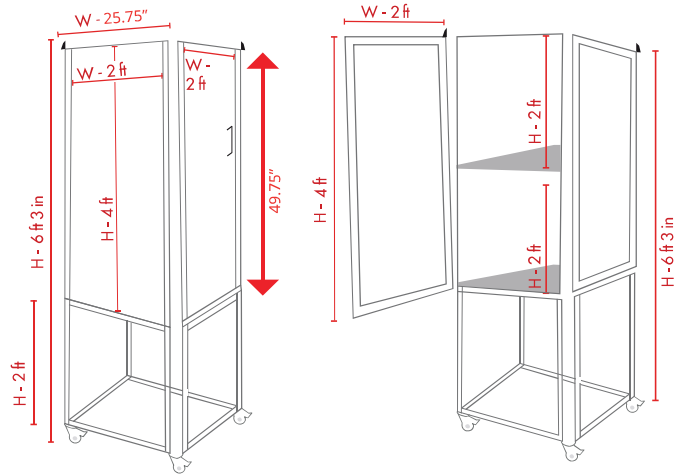

Size Plain Printed 1 Side Printed 2 Sides Printed 3 Sides Printed 4 Sides

Midi MCUBS002 MCUBSCP12 MCUBSCP22 MCUBSCP32 MCUBSCP42

Mobile Whiteboard Cube Cabinet Maxi



The Maxi version offers extra whiteboard space with each whiteboard side measure 2 ft x 6 ft, width x height.

Features

- 4 Sided whiteboard solution
- Each whiteboard measures 2 ft x 6 ft w x h
- Supplied with 4 x heavy duty wheels, 2 are lockable
- Includes 3 shelves (including base)
- Usable with magnetic accessories
- Custom options available

Specification

Surface Type	Magnetic Coated Steel
Surface Guarantee	10 Year guarantee
Whiteboard Surfaces	4
Whiteboard Size	2 ft x 6 ft
Shelves	3 (including base)
Dry Eraseable	Yes
Frame	Aluminum 1 in x 1 in
Height	6' 3"
Casters	4 x Casters (2 x Lockable)

Custom Printed Dye Sublimation Whiteboard



Custom Printed Header Whiteboard



Plain Magnetic Whiteboard

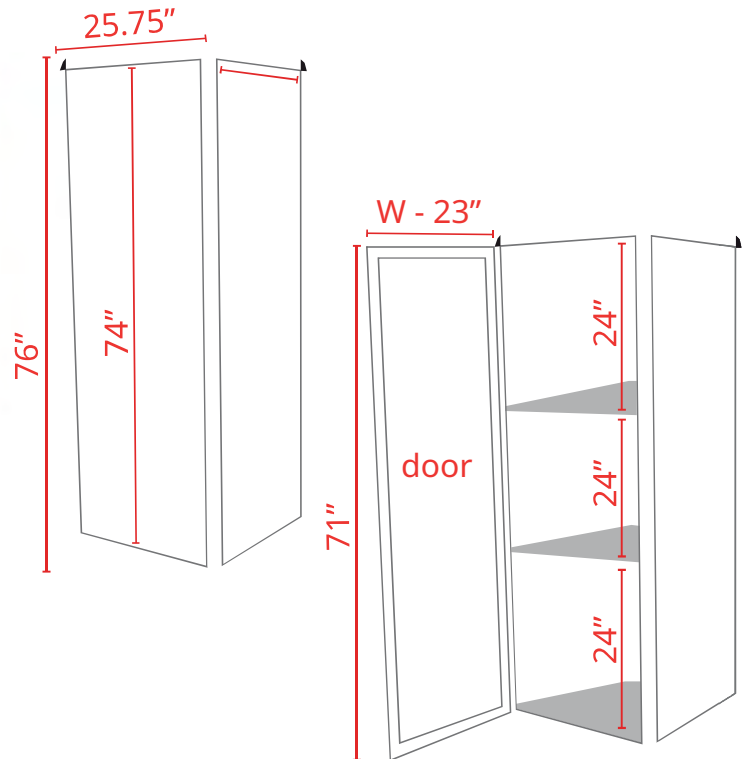

Size Plain Printed 1 Side Printed 2 Sides Printed 3 Sides Printed 4 Sides

Maxi MCUBE002 MCUBESCP12 MCUBESCP22 MCUBESCP32 MCUBESCP42

Mobile Whiteboard Meeting Station Midi



Looking to create a meeting area? This double sided meeting station is made up of 3 quality magnetic whiteboards so with 6 total writing surfaces, it is great for hosting meetings, team collaborations and projects.

Features

- 3 Double sided whiteboards
- An overall writing surface of 14 ft x 4 ft
- Wheel plates supplied with 3 x heavy duty wheels per base, 1 of which is lockable per base

Specification

Surface Type	Magnetic Coated Steel
Surface Guarantee	10 Year guarantee
Whiteboard Surfaces	6
Central Panel Size	6 ft x 4 ft
Outer Panel Sizes	4 ft x 4 ft
Dry Eraseable	Yes
Frame	Aluminum 1 in x 1 in
Total Height	6' 3"
Total Width	15' 5"
Casters	12 x Casters (4 x Lockable)



Custom Printed Dye Sublimation Whiteboard



Custom Printed Header Whiteboard



Plain Magnetic Whiteboard

Size	Plain	Central Panel Only	Central and Inner Wings	Central and All Wings	All Surfaces Printed
Midi	M3CM2S420	M3SCPM2S41S	M3SCPM2S42S	M3SCPM2S43S	M3SCPM2S44S



Mobile Whiteboard Meeting Station Maxi



The Maxi version is comprised of 3 x portrait whiteboards, each whiteboard measuring 4 ft x 6 ft, width x height. The total width of the unit is 13' 5".

Features

- 3 Double sided whiteboards
- An overall writing surface of 12 ft x 6 ft
- Wheel plates supplied with 3 x heavy duty wheels per base, 1 of which is lockable per base

Specification

Surface Type	Magnetic Coated Steel
Surface Guarantee	10 Year guarantee
Whiteboard Surfaces	6
Central Panel Size	4 ft x 6 ft
Outer Panel Sizes	4 ft x 6 ft
Dry Eraseable	Yes
Frame	Aluminum 1 in x 1 in
Total Height	6' 3"
Total Width	13' 5"
Casters	12 x Casters (4 x Lockable)



Custom Printed Dye Sublimation Whiteboard



Custom Printed Header Whiteboard



Plain Magnetic Whiteboard

Size	Plain	Central Panel Only	Central and Inner Wings	Central and All Wings	All Surfaces Printed
Maxi	M3CM2L420	M3SCPM2L41S	M3SCPM2L42S	M3SCPM2L43S	M3SCPM2L44S

Obeya Whiteboard Rooms

Obeya Rooms

In this section you will see different ways to create an Obeya room. The free standing Lean Visual Corner can be made to measure and supplied with printed panels and accessories. The economical option of Large Cut & Join Whiteboards can also be used to create a large magnetic whiteboard surface.

Lean Visual Corner



Our conceptual **Lean Visual Corner**, known as Obeya, can be used to facilitate problem solving, improve productivity and implement continuous improvement initiatives.

- Can be made with fully custom printed whiteboard panels
- Custom Printed Header options available
- Custom structures & options available
- Installation service available, **contact us for more information**

Front View

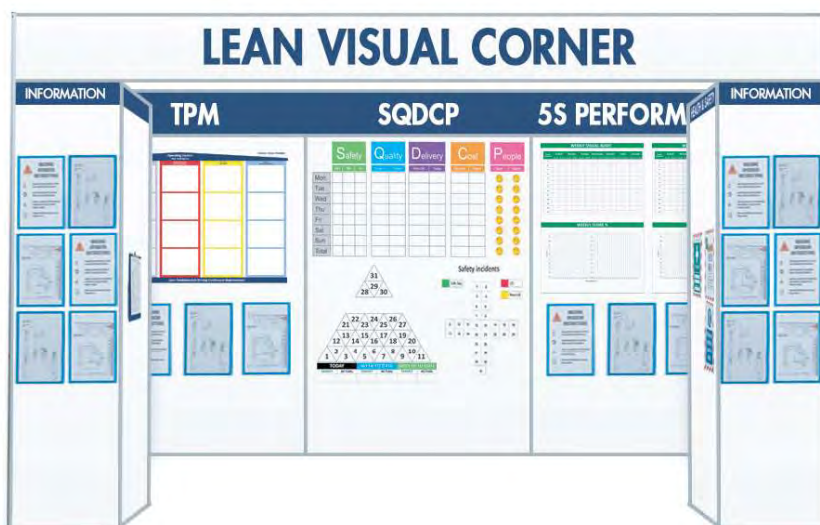

Side Profile

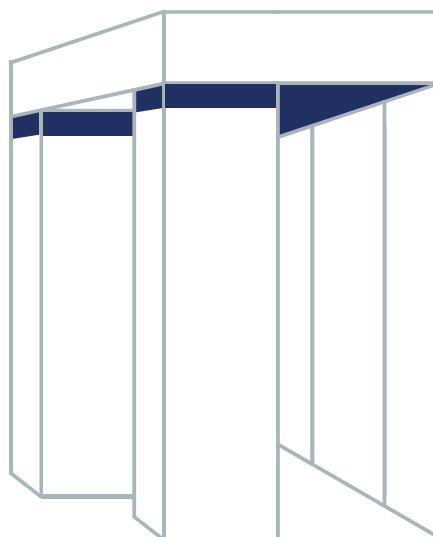

Contact customer services for more information

Tel: (888) 393-7785

Email: sales.usa@magiboards.com

Aerial View

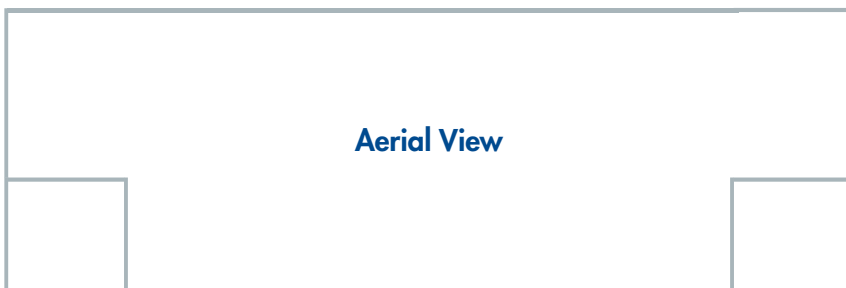

*The image provided above are not to scale and are for reference only. Actual product may vary.

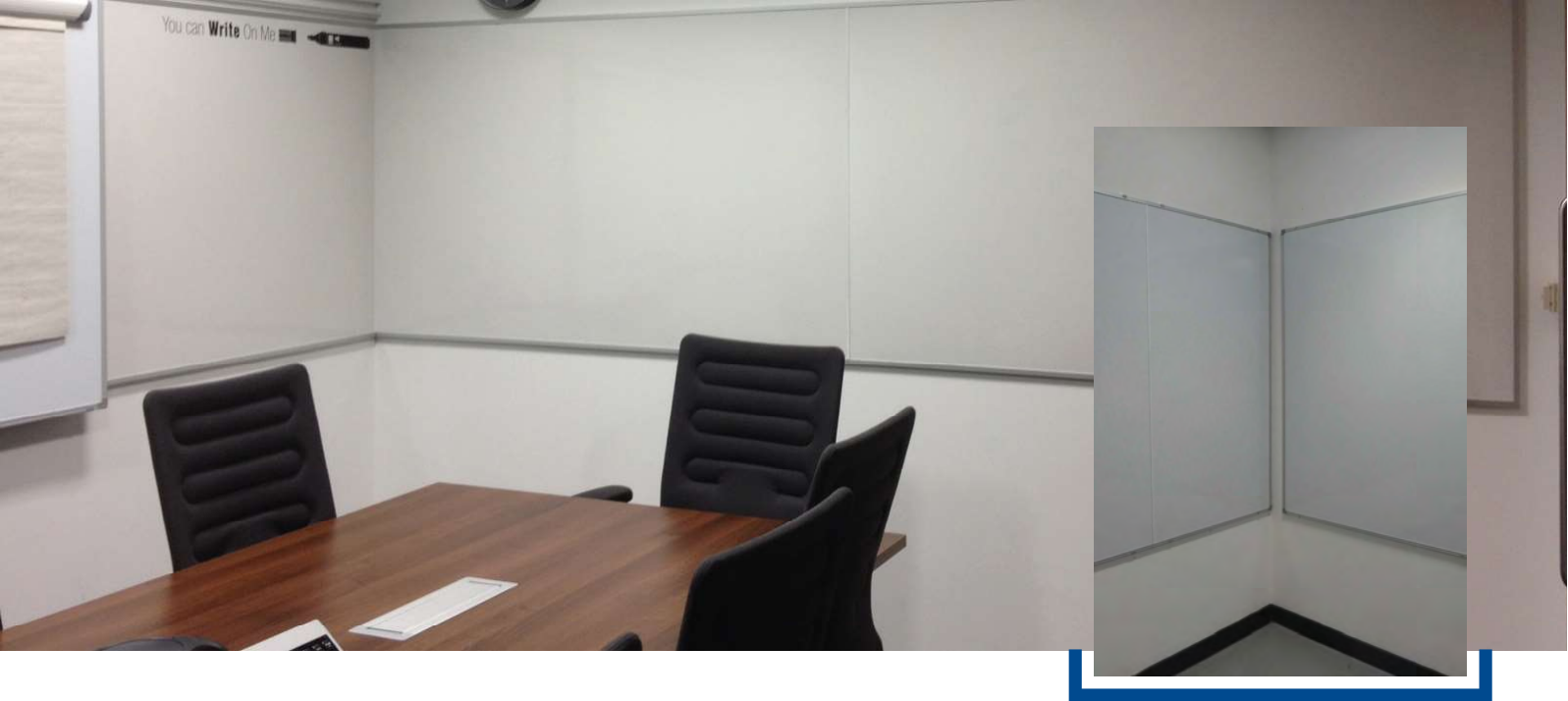

Large Cut & Join Whiteboards

Are you looking for a cost effective large magnetic whiteboard that is bigger than 8 ft x 4 ft? Magiboards very often supplies **cut and join** magnetic whiteboards. With its unique white aluminum one frame surround and link-able panels, we can achieve wall to wall coverage. The boards are joined together with a discreet 0.4 inch wide 'H' section joining piece, made from anodized aluminum. Custom printing is available on the coated steel surface.

- Create a large whiteboard size suitable for you
- Easy & economical to transport
- Looks professional with a one frame surround
- Allows for large whiteboard solutions to get through doors and corridors
- Available with top quality coated steel surface
- **Custom printing available on coated steel surface**

Coated Steel Whiteboards

With its 10 year surface guarantee, our magnetic coated steel whiteboard is the best in its class. Compatible with all our magnetic whiteboard accessories.

- Accepts all magnetic accessories
- 10 year surface guarantee
- **Custom printing available**

Simple & Easy Installation

Your large magnetic whiteboard will arrive in pre cut whiteboard panels with the frame already attached. The H section is also attached to one of the panels for easy installation.



Lean Whiteboard Accessories

We supply a huge range of accessories to complement your visual management whiteboards and notice boards. From writing and erasing accessories to paper holders and magnets / magnetic indicators, our range is wide and diversified to offer you the best accessory choices. Custom options are available.

Paper Holders

Magnetic Document Holder Windows	34
Magnetic Document Holder w/Hazard Markings	34
Self Adhesive Document Holder Windows	35
Ring Binders	36
Acrylic Poster Sleeves	36
Magnetic Photo Holders	36
Magnetic Window Headers	37
Clipboard with Magnetic Attachment	37
Paper Holder Magnets	37

Magnetic Indicators

Magnetic Flexible Vinyl Indicators	38
Magnetic Printed Arrows	38
Vinyl Dry Erase Notes	38
Magnetic Indicators	39
Printed Memo Magnets	39
Custom Printed Magnets	40

Magnetic Header Labels

Magnetic Safety Cross & SQDC Trophy Magnets

General Whiteboard Accessories

Whiteboard Starter Kit	42
Scrum Kit	42
Dry Erase Whiteboard Marker Pens	42
Pen Holders & Accessory Trays	43
Cleaning Products	43
Gridding Tape	44
Heavy Duty Wheels	44
T Card System	45



Document Holders

Solo Magnetic Document Holder Window Frame

Magnetic document holder windows are great for keeping papers in place and preventing unwanted tampering, as well as give a professional look to your whiteboard. There are magnetic strips on the back of three of the borders which allows for the paper holder to stick to any magnetic surface and also means that putting in the sheets and taking them out is a very simple operation.



Size	Quantity	Color	Code
Tabloid	6	Black	AW1300BLA
Tabloid	6	Blue	AW1300BLU
Tabloid	6	Red	AW1300RED

Size	Quantity	Color	Code
Letter	12	Black	AW1400BLA
Letter	12	Blue	AW1400BLU
Letter	12	Red	AW1400RED



Solo Magnetic Document Holder with Hazard Markings

Size	Quantity	Color	Code
Letter	6	Black / Yellow	AWH1400BLA
Letter	6	Green / White	AWH1400GRE
Letter	6	Red / White	AWH1400RED

Document holder windows with a hazard marking border are widely used in factories and are ideal for displaying Health & Safety notices or other important information. There are magnetic strips on the back of three of the borders which allows for the paper holder to stick to any magnetic surface.

Duo Self Adhesive Document Holder Window Frame

Our self adhesive windows are designed to be used on any smooth surface, such as windows, doors or whiteboards. When used on a glass surface, the paper holder can be a two-sided display. Once applied to a surface the window stays firmly in place and is non removable.

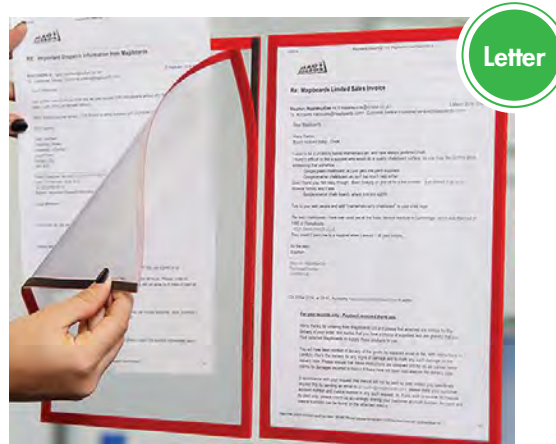

Size	Quantity	Color	Code
Tabloid	3	Black	AW60300BLA
Tabloid	3	Blue	AW60300BLU
Tabloid	3	Red	AW60300RED

Size	Quantity	Color	Code
Letter	6	Black	AW60400BLA
Letter	6	Blue	AW60400BLU
Letter	6	Red	AW60400RED

Document Holder Windows Sizes

All of our document holder windows fit a full sheet of size appropriate paper in the see through window, perfect to display printed work or data. Below you will find a size guide, including overall sizes, internal viewable window size and the width of the colored border.

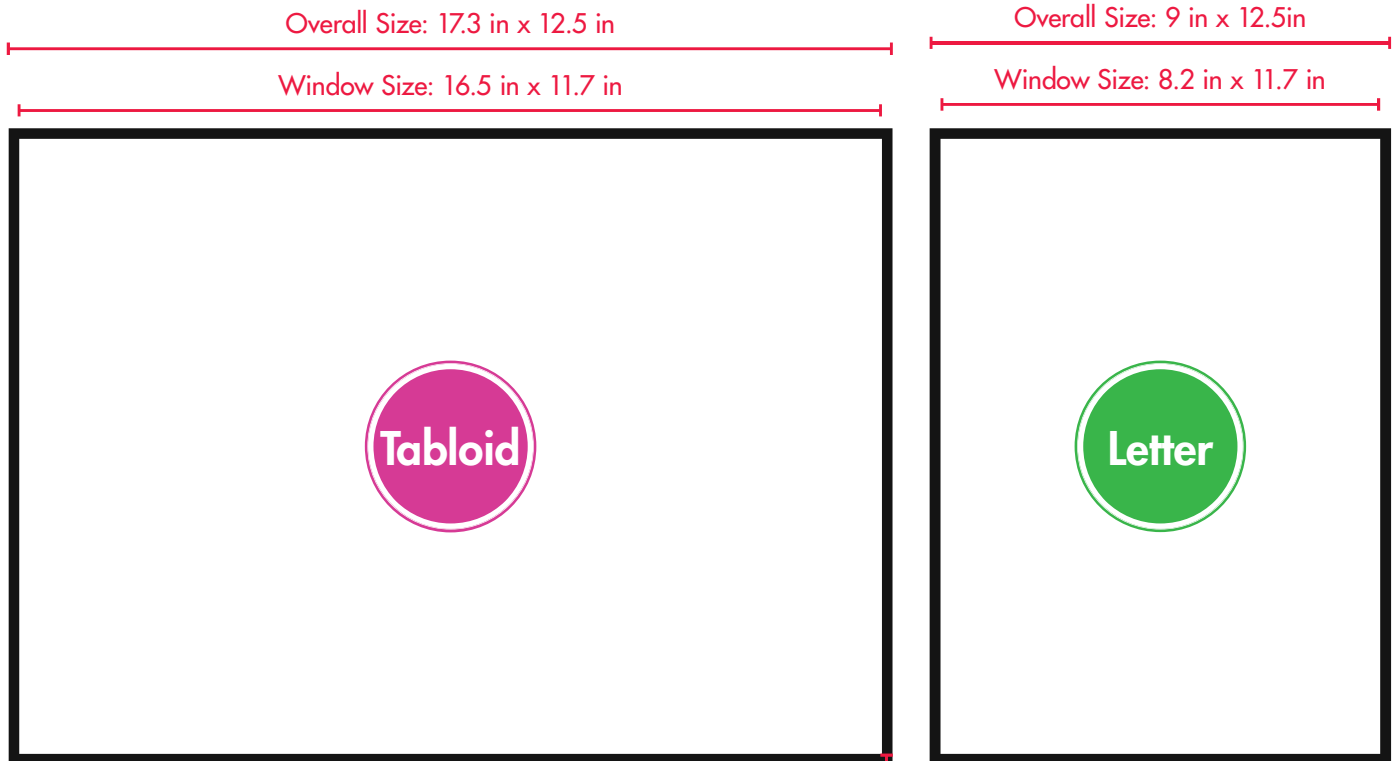

Border: 0.4 in

Ring Binder - Fixed

We can attached the ring binder to your whiteboard in our factory.



Letter

Size	Quantity	Holes	Code
Letter	1	2	A00265
Letter	1	3	A00365

Ring Binder - Magnetic Attachment

The ring binder is supplied with extra strong magnets which attach to any surface accepting magnets.



Letter

Size	Quantity	Holes	Code
Letter	1	2	A00265M
Letter	1	3	A00365M

Tip!

2 Hole ring binders are for displaying Letter portrait paper.

3 Hole ring binders can for displaying Letter landscape and Tabloid portrait paper.

Magnetic Photo Holder



Size	Quantity	Code
2" x 3"	10	APH5375M10



Simply print your own photos add to the holders. Each photo holder measures 2 in x 3 inch and are supplied in packs of 10. **Custom sizes available.**

Magnetic Window Headers

Magnetic windows headers are a great product for creating a test design for your visual management board. The viewable area in each header accepts a full width Letter portrait / landscape & Tabloid portrait paper.

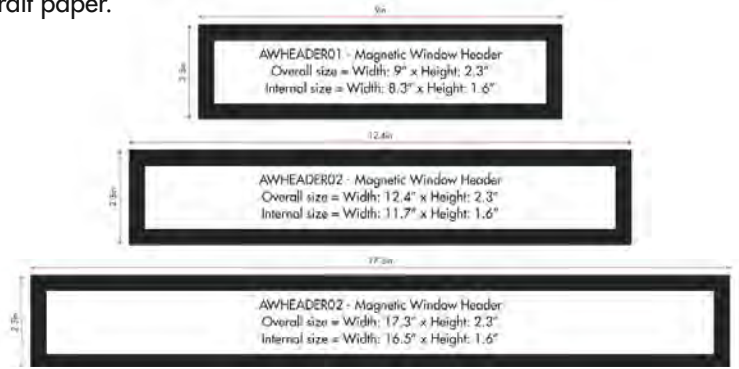

Size	Quantity	Color	Code
9" x 2.3"	3	Black	AWHEADER01BLA
9" x 2.3"	3	Blue	AWHEADER01BLU
9" x 2.3"	3	Red	AWHEADER01RED
12.4" x 2.3"	3	Black	AWHEADER02BLA
12.4" x 2.3"	3	Blue	AWHEADER02BLU
12.4" x 2.3"	3	Red	AWHEADER02RED
17.3" x 2.3"	3	Black	AWHEADER03BLA
17.3" x 2.3"	3	Blue	AWHEADER03BLU
17.3" x 2.3"	3	Red	AWHEADER03RED

9 in x 2.3 in

- Letter Portrait

12.4 in x 2.3 in

- Letter Landscape
- Tabloid Portrait

17.3 in x 2.3 in

- Letter Landscape

Clipboard with Magnetic Attachment

The clipboard holds up to 40 Letter sheets at any one time. The magnetic attachment can be used on any magnetic surface

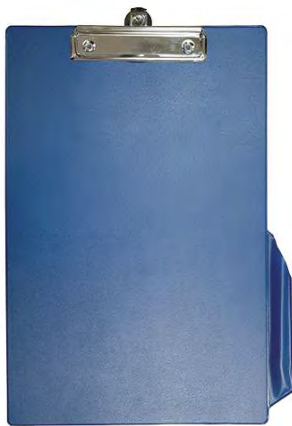

Size	Quantity	Color	Code
Letter	2	Blue	AC1402BLU

Paper Holder 1.4 in Magnets

Our 1.4 inch memo magnets are ideal for holding paper on a whiteboard and are great for providing large visual indicators.

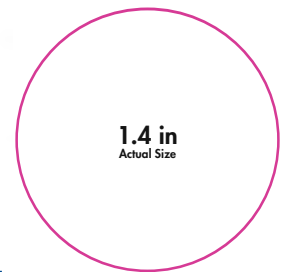

Size Ø	Quantity	Color	Code
1.4"	10	Assorted	A00038ASS
1.4"	10	Black	A00038BLA
1.4"	10	Blue	A00038BLU
1.4"	10	Green	A00038GRE
1.4"	10	Red	A00038RED
1.4"	10	White	A00038WHI
1.4"	10	Yellow	A00038YEL

Magnetic Indicators

Printed Magnetic Flexible Vinyl Indicators

The flexible vinyl magnetic indicators are made from extra thick vehicle grade material which makes them easy to handle. Each sheet has 64 magnets. Each square is 1.4 in x 1.4 inch.

Custom sizes & designs available.

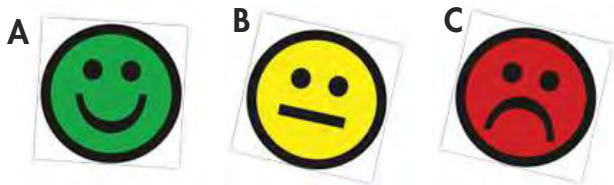

Size	Quantity	Color	Code
1.4"	Sheet of 64	Green Smiley Face (A)	A044FACEGRE
1.4"	Sheet of 64	Yellow Neutral Face (B)	A044FACEYEL
1.4"	Sheet of 64	Red Sad Face (C)	A044FACERED



Size	Quantity	Color	Code
1.4"	Sheet of 64	Green Checkmark (D)	A044TICKGRE
1.4"	Sheet of 64	Yellow Question Mark (E)	A044QUESYEL
1.4"	Sheet of 64	Black / Yellow Warning Triangle (F)	A044EXCLBY
1.4"	Sheet of 64	Red / White Warning Triangle (G)	A044EXCLRW
1.4"	Sheet of 64	Red X (H)	A044CROSSRED

Magnetic Printed Arrows

Flexible vinyl printed arrow magnetic indicators are supplied in sheets of 20 and each square is 1 in x 1 inch.

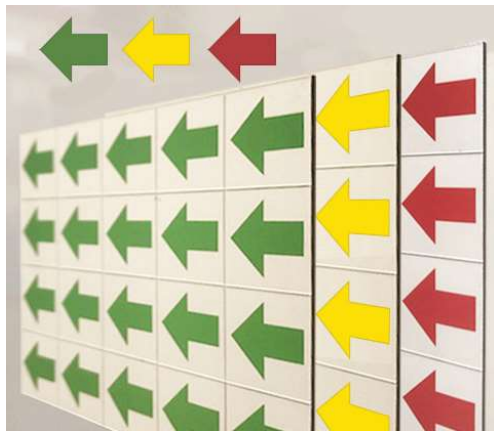

Size	Quantity	Color	Code
1" x 1"	20	Assorted	A045ARWASS
1" x 1"	20	Green	A045ARWGRE
1" x 1"	20	Yellow	A045ARWYEL
1" x 1"	20	Red	A045ARWRED

Magnetic Dry Erase Notes

Magnetic dry erase notes measure 4 in x 4 inch and can be written on using dry erase markers. Magnetic notes are often used in Scrum and can be used to give a priority to certain projects.

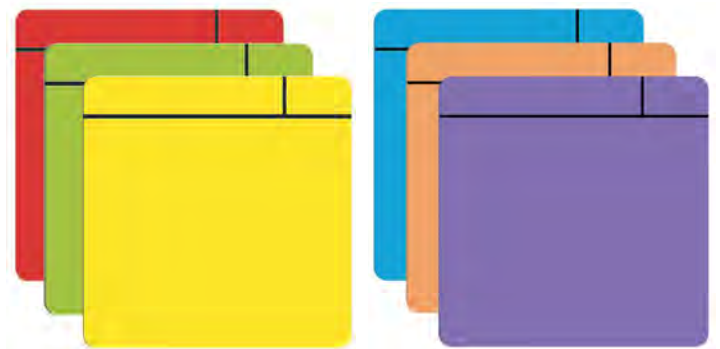

Size	Quantity	Color	Code
4" x 4"	5	Blue	A046POSTBLU
4" x 4"	5	Green	A046POSTGRE
4" x 4"	5	Orange	A046POSTORA
4" x 4"	5	Purple	A046POSTPUR
4" x 4"	5	Yellow	A046POSTYEL
4" x 4"	5	Red	A046POSTRED

Magnetic Indicators

Our 0.4 in, 0.8 in & 1 inch memo magnets are perfect magnetic indicators for your whiteboard. Red, green and yellow magnets can be used in a traffic light system.

Available in packs of 10 in a range of colors.



0.4 in
Actual Size

0.8 in
Actual Size

1 in
Actual Size



Size Ø	Quantity	Color	Code
0.4"	10	Assorted	A00056ASS
0.4"	10	Black	A00056BLA
0.4"	10	Blue	A00056BLU
0.4"	10	Green	A00056GRE
0.4"	10	Red	A00056RED
0.4"	10	White	A00056WHI
0.4"	10	Yellow	A00056YEL

Size Ø	Quantity	Color	Code
0.8"	10	Assorted	A00057ASS
0.8"	10	Black	A00057BLA
0.8"	10	Blue	A00057BLU
0.8"	10	Green	A00057GRE
0.8"	10	Red	A00057RED
0.8"	10	White	A00057WHI
0.8"	10	Yellow	A00057YEL

Size Ø	Quantity	Color	Code
1"	10	Assorted	A00238ASS
1"	10	Black	A00238BLA
1"	10	Blue	A00238BLU
1"	10	Green	A00238GRE
1"	10	Red	A00238RED
1"	10	White	A00238WHI
1"	10	Yellow	A00238YEL

Printed Memo Magnets

Each magnet measures 1.4 inch in diameter and is supplied in a pack of 5.

The magnets stand 0.3 in from the whiteboard and are easy to handle.



Size Ø	Quantity	Color	Code
1.4"	5	Green Happy Face (A)	A041FACEGRE
1.4"	5	Yellow Neutral Face (B)	A041FACEYEL
1.4"	5	Red Sad Face (C)	A041FACERED



Size Ø	Quantity	Color	Code
1.4"	5	Green Tick (D)	A041TICKGRE
1.4"	5	Yellow Question Mark (E)	A041QUESYEL
1.4"	5	Red Exclamation Point (F)	A041EXCLRED



Double Sided

Double Sided Printed Magnets

Sold as a pack of 5, double sided flexible vinyl performance magnets are great for visual management boards and are made from extra thick vehicle grade material. 2 inch diameter. Simply flick the magnet over - No need to store extra magnets.

Size Ø	Quantity	Color	Code
2"	5	Face	A244FACE
2"	5	Tick / Exclamation Point	A244TICEXC

Custom Printed Magnetic Accessories

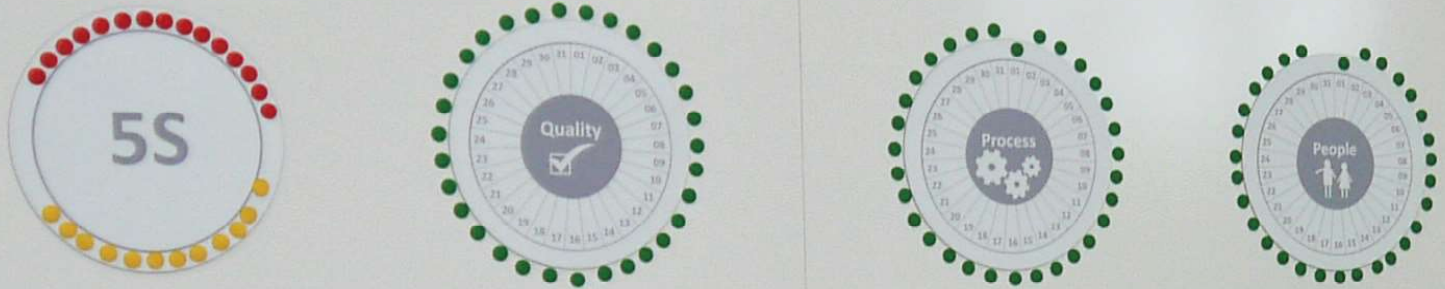

Any Size • Custom Designs • Custom Shapes

Create your own custom printed magnets with us! Create any size, any design and any shape magnet to suit. Full color printing available with an optional dry erase finish.

- Custom design to your specification
- Create magnets in any size for any quantity
- Optional dry erasable finish

Step 1:

Simply let us know what size magnet you require, the quantity you will be ordering and a short brief / sketch / mock up of your design and we will handle the rest.

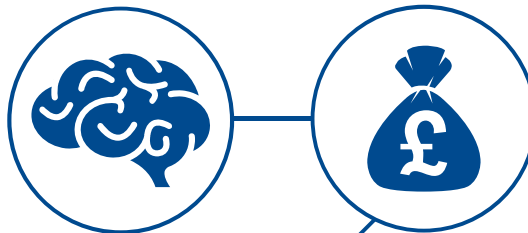

Step 2:

We will then send you a tailored quote based around your proposed specification and order quantity

Step 3:

After approving the quote and confirming the order, Magiboards will make a PDF proof for you to sign off (or amend) before the magnets go into production.

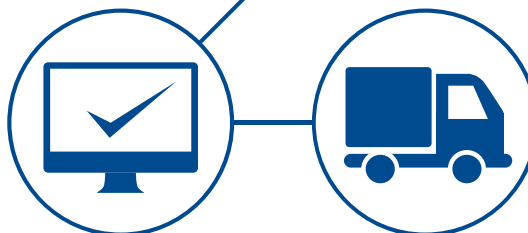

Step 4:

Following approval of the proof, Magiboards will then produce and deliver your magnets to you. Just like that, you will have your very own custom printed magnets

Custom Printed Magnetic Headers

Created using a vinyl material with a magnetic backing, we can make special custom magnetic headers to suit your board design. Our graphic designers will work with you on sizing and design so your lean board works perfectly for you.



*Example printed header design

Magnetic Dry Erase Labels

These magnetic labels attach to any magnetic surface. The front can be used with a dry erase whiteboard marker pen and is easy to clean. Ideal for attendance boards, photo boards and name tags.



Size	Quantity	Code
5.5" x 1"	10	A046LAB01

Magnetic Safety Cross

The safety cross is printed onto a magnetic coated steel dry erase sheet and backed with a magnetic backing which can be used on any magnetic whiteboard surface.

- Usable with 1 inch magnetic indicators
- Usable with dry erase marker pens

THIS MONTH		THIS YEAR		1	2	We're Thinking and Working SAFELY Every Day™				
				3	4					
DAYS SINCE LAST RECORDABLE INJURY				5	6					
				7	8					
9	10	11	12	13	14	15	16	No Incidents ■ Near Miss or First Aid ■ Medical Treatment, Restricted Duty or Lost Time Injury ■ Upcoming Tests / Associated Risks ⚠		
17	18	19	20	21	22	23	24			
		25		26						
		27		28						
		29		30						
		31								

Size	Quantity	Code
11.6" x 10.8"	1	ACCESAFMID
14.25" x 13.6"	1	ACCESAFMAX

SQDC Trophy Magnets

A set of 5 trophy magnets to celebrate the "best of the Best" in 5S, Safety, Quality, Delivery and Cost. Each magnet is 4 x 6 inch.



Size	Quantity	Code
4" x 6"	Set of 5	A0TROPHY

General Whiteboard Accessories



Whiteboard Starter Kit

Code

AW00086

Included

- 4 x Disposable dry erase marker pens
- 1 x Pen tray holder (4 Space)
- 5 x Multi colored memo magnets
- 3 x Microfiber cloths
- 1 x 9 fl oz MagiClean cleaning fluid
- 1 x Magnetic whiteboard eraser
- 1 x Pack of 10 eraser refills



Scrum Kit

Code

AW00089

Included

- 6 x Pack of 5 magnetic dry erase notes in 6 colors (green, red, yellow, blue, orange and purple)
- Pack of 10 x 0.8" black memo magnets
- 1 x 0.12" Black self adhesive gridding tape
- 1 x Sheet of 1.4" magnetic X & warning triangles
- 5 x Printed magnetic scrum headers (5.9" x 1.97")



Dry Erase Whiteboard Marker Pens

A pack of 10, disposable dry erase marker pens available with a bullet tip in a range of colors.

Assorted pack includes:

- 2 x Blue
- 2 x Green
- 2 x Red
- 4 x Black

Type	Quantity	Color	Code
Bullet Tip	10	Assorted	A00004ASS
Bullet Tip	10	Black	A00004BLA
Bullet Tip	10	Blue	A00004BLU
Bullet Tip	10	Green	A00004GRE
Bullet Tip	10	Red	A00004RED

Whiteboard Pen & Accessory Holders



Size (WxHxD)	Code
4" x 4.7" x 2"	A00087

Midi

Magnetic attachment for attaching to a magnetic whiteboard. Will fit 10 x Magiboards whiteboard marker pens.



Size (WxHxD)	Code
11.8" x 4" x 2.7"	A00088

Maxi

3 Separate sections where you can neatly store your pens, magnets and other accessories. Magnetic attachment for attaching to a magnetic whiteboard.



Size (WxHxD)	Code
3" x 4" x 2"	A00058

4 Space Pen Holder

4 Space pen holder to suit Magiboards dry erase marker pens.

*Whiteboard marker pens not included

MagiClean Whiteboard Cleaning Fluid

New and improved formula for our environmentally friendly, non-flammable, solvent and salt free cleaning fluid.



Size	Quantity	Code
9 fl oz	1	A00006

Magnetic Whiteboard Eraser & Refills



Size	Quantity	Code
6" x 2.4"	1	A00912

Magnetic Eraser

Magnetic whiteboard eraser in blue. Provides a large surface area for erasing with an easy to grip handle for comfort.



Quantity	Code
Pack of 10	A00913

Refills

A pack of 10 eraser refills only. For use with your Magiboards magnetic whiteboard eraser.





See Video

Easy Cleaning Guide for your Whiteboard

★★★★★

Magnetic Flipchart Attachment

Our flip chart has flexible paper suspension points which allow you to use any size flip chart pads. The flip chart will attach to any magnetic surface.

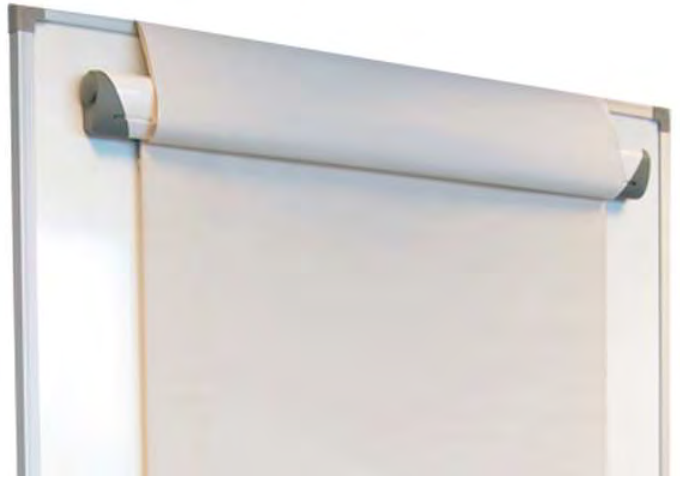

Size	Quantity	Attachment	Code
27.56"	1	Magnetic	FZ0005

Self Adhesive Gridding Tape in Dispenser

Available in 0.06 inch and 0.12 inch tape widths, the self adhesive gridding tape comes supplied in an easy to use blue dispenser. Each dispenser contains 33 feet of tape. The tape is available in black or red.

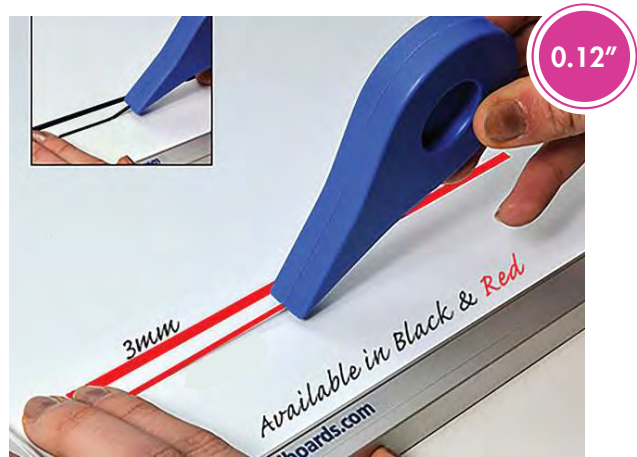
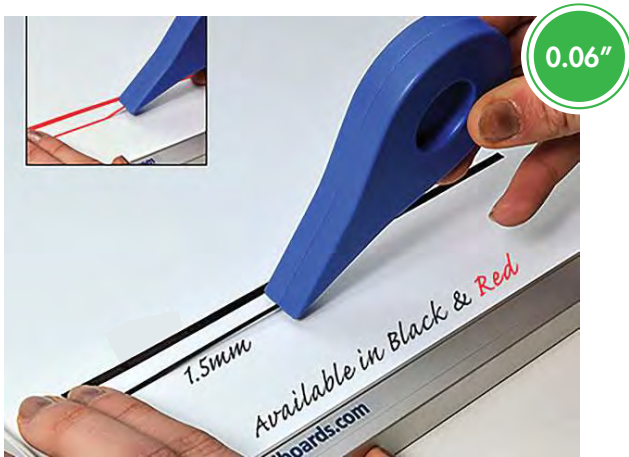

Size (width)	Length	Color	Code
0.06"	33 feet	Black	A00025BLA
0.06"	33 feet	Red	A00025RED

Size (width)	Length	Color	Code
0.12"	33 feet	Black	A00026BLA
0.12"	33 feet	Red	A00026RED



Magnetic Whiteboard 0.4 inch Tape

Magnetic whiteboard tape is for use on a magnetic whiteboard or any magnetic surface. Supplied on a roll and can easily be cut with a pair of scissors.



Size (width)	Length	Color	Code
0.4"	10 feet	Assorted	A00023ASS
0.4"	10 feet	Black	A00023BLA
0.4"	10 feet	Red	A00023RED
0.4"	10 feet	Yellow	A00023YEL
0.4"	10 feet	Blue	A00023BLU
0.4"	10 feet	Green	A00023GRE

Heavy Duty Wheels

Upgrade the casters on your mobile stand to heavy duty wheels. Includes a set of 4 wheels, 2 of which are lockable. This item is assembled to your mobile stand in our factory before dispatch.



Quantity	Attachment	Code
Set of 4	Made in Factory	AM0004

T Card System

We can build in a T Card Panel into your custom printed whiteboard. These can be fully fitted in our factory and supplied to you complete with T Cards to suit. Our in-house design studio will design and work out the most economical size to suit your needs.

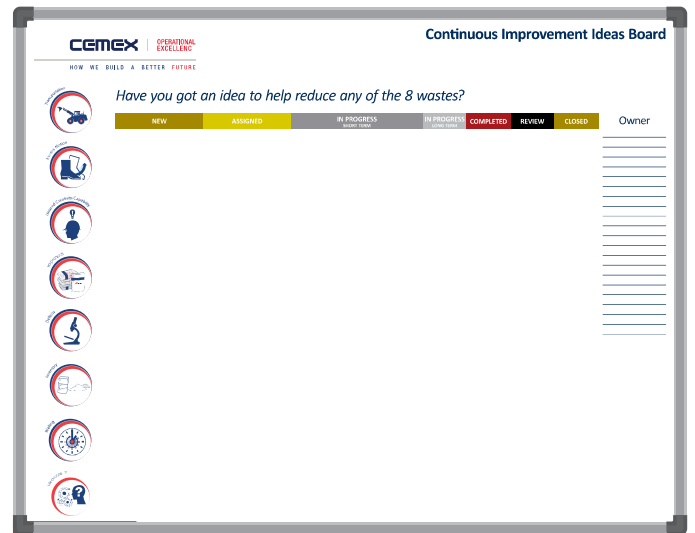
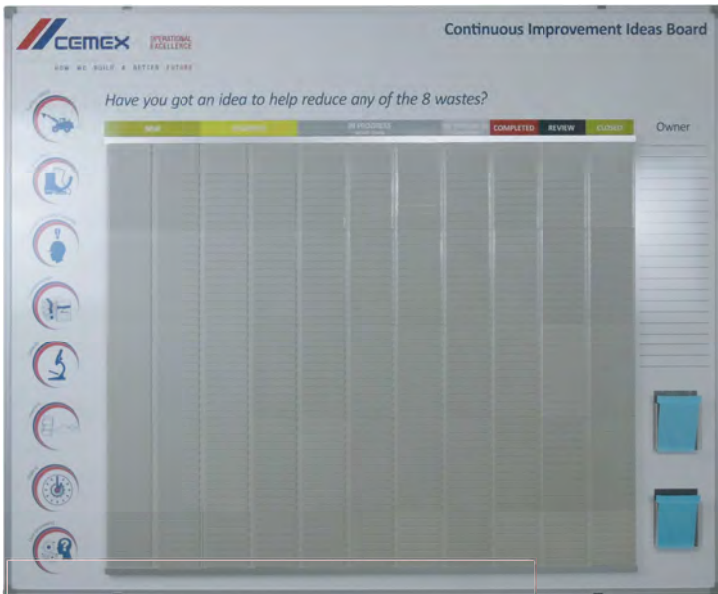

Finished Board with T Card system installed

Artwork

MagiShape ECO Tack Boards

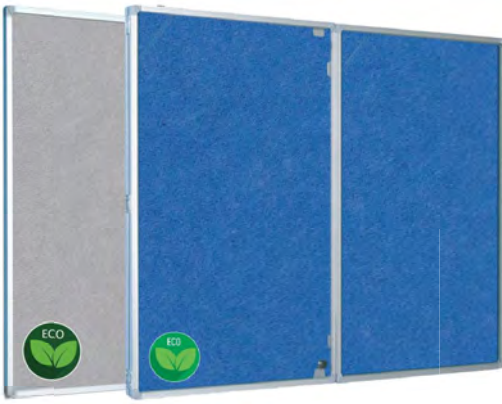

MagiShape Tack Boards provide all the functionality of a regular tack board, with its excellent pin retention and hook & loop accessory usability, as well as the added benefit of being ECO friendly. MagiShape is made from 100% recycled material - 65% recycled post consumer waste plastic and 35% recycled pre consumer waste.

Features

- ECO Friendly, made from 100% recycled consumer waste plastic
- Accepts push pins
- Self colored board - No fabric coverings!
- Frameless boards can be butted together to create a larger notice board surface
- All wall fixings supplied

Specification

Surface Type	Recycled Polyester
Surface Guarantee	2 Year guarantee
Frame	Aluminum / Frameless
Doors	Lockable, Tamperproof, Shatterproof APET
ECO Friendly	Made from 100% recycled material

Aluminum Frame



Size (feet)	Code
3' x 2'	NX1A02
4' x 3'	NX1A04
6' x 4'	NX1A07

Frameless



Size (feet)	Code
3' x 2'	NX1A02
4' x 3'	NX1A04
6' x 4'	NX1A07

Lockable ECO Tack Board

Complete with see through lockable, tamperproof doors made from shatterproof APET that offer excellent visibility. All boards are supplied with two locks and two sets of keys (4 Keys total).

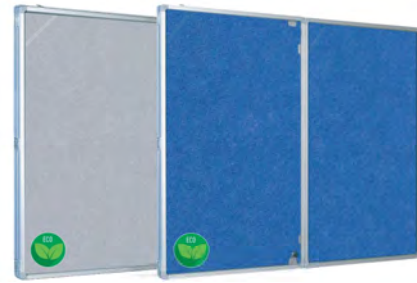

Size (feet)	Doors	Orientation	Code
4' x 3'	1	Landscape	GX1A04L
6' x 4'	2	Landscape	GX2A07L



An ECO Friendly Product

- 65% Recycled post consumer waste plastic
- 35% Recycled pre consumer waste plastic
- 0% Waste material for each panel

Custom
Headers
Available

Printed Header Features

- Custom, full color printing available



MAGISHAPE

Swatches Available



Contact Us

UK Office

Magiboards Ltd 

Unit F, Stafford Park 12,
Telford, Shropshire,
TF3 3BJ



Email: sales@magiboards.com

Tel: 01952 292111

Web: magiboards.com

We're Social!



USA Office



Magiboards USA Inc

1101 Sussex Blvd,
Suite #5, Broomall,
PA 19008

Email: sales@magiboardsusa.com

Tel: (888) 393-7795

Web: magiboardsusa.com

We're Social Too!



Magiboards 

WHAT OUR CUSTOMERS ARE SAYING

I have found dealing with Magiboards a very pleasant experience. It all went very smoothly from quoting, digital proofing, through to receiving the boards at our sites throughout the UK. The boards are of excellent quality and come with a 10 year guarantee, which is a bonus as they will get used a lot. The printing is very clear and they are easy to keep clean.

- Orhan Z



We were really impressed with the whiteboard that you produced for us. The service was brilliant and the sales team was extremely helpful.

- Gemma B



Just like to say thank you for a great job on the boards, they look fantastic!! I will be in touch soon to place an order for custom board magnets

- Neil P



The whole team think our Safety, Quality & People Development custom printed boards look great and we are looking forward to starting phase 2 with Magiboards.

- Andrew W



Great service, thank you. Boards have been effective when implemented and we are looking at other designs to control other areas of our business. We will be looking to do more business with yourselves to support our needs.

- Peter S



As a returning customer to Magiboards, I am very happy with the custom printed whiteboard that you designed for me. It is excellent quality as ever and I already want to order another board.

- David R



I am very pleased with the boards we have received from Magiboards. Auditors have commented on them and our C.I Manager wants to use you to build our DMS boards in the near future.

- Martin H



Magiboards are '5 Star' as reviewed on Google

(888) 393-7795

sales@magiboardsusa.com



Website

Magiboards USA Inc

1101 Sussex Blvd

Suite #5

Broomall

PA 19008

